

HYDAC INTERNATIONAL

**Automatic
Back-Flushing Filter
AutoFilt® RF10.**



Back-flushing filter AutoFilt® by **HYDAC**



The Challenge.

The conventional technology of automatic back-flushing filters already exists for decades but nevertheless the requirements for performance, efficiency and environmental friendliness of the systems have increased enormously in the recent years.

Almost all "conventional back-flushing filters" are pressure-driven systems. This means that these systems require a certain operating pressure on the clean side of the filter to provide the force to flush out the contamination via the back-flush line. The higher the pressure, the more effective the cleaning. Other factors which limit the use of conventional filters are high contamination loads, which are particularly common in ballast water applications, or counter-pressure in the back-flush lines, which usually have the effect of significantly reducing or totally negating the effectiveness of the back-flushing.

The key question is therefore: What happens if the relevant pressure conditions are not met, the counter pressure in the back-flush line is too great, or the dirt load is too high? In these cases "conventional back-flushing filters" cannot be used.

The Solution.

HYDAC's automatic back-flushing filter in the AutoFilt® series, have already been proven in thousands of industrial applications, demonstrating their reliable performance capability.

But the new patented technology in the HYDAC AutoFilt® RF10 breaks new ground and offers a solution for applications which stretch conventional back-flushing filters to the limit.

Service range of the AutoFilt® RF10:

- **Back-flushing independent of pressure on clean side of filter**
- **Dependent only on the inlet pressure**
- **Highly effective back-flushing with low pressure conditions and long back-flush lines**
- **With its highly effective cleaning, the filter is suitable for high dirt loads and also for surges in contamination**



Element technology.

The filter elements are the heart of the filter. They determine the performance. AutoFilt® RF10 therefore uses only the best filter materials, setting new standards of stability, durability and cleanability:

Conical filter elements

SuperMesh filter material

SuperFlush technology

Isokinetic filtration and back-flushing.

The special conical shape and arrangement of the filter elements allow even flow, resulting in low pressure drop and complete cleaning over the entire element surface.

Fewer back-flushing cycles

Lower back-flushing losses

Filtration

Back-flushing

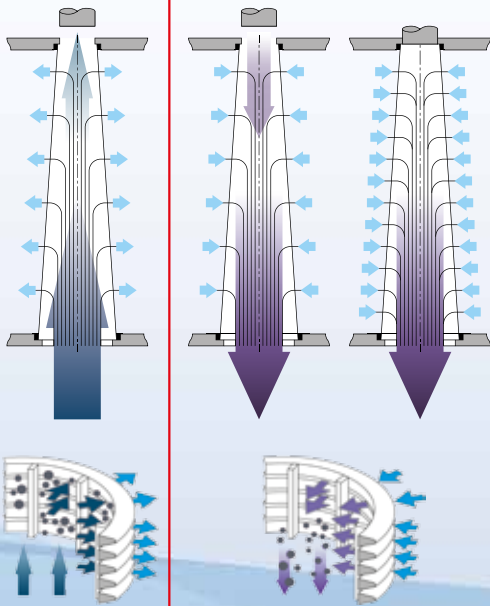

Effectiveness of back-flushing with new AutoFilt® RF10 technology.

Filter elements: cylindrical vs. conical



Selection of filter materials.



Wire mesh SuperMesh

Material: stainless steel

Filtration rating: 25 µm to 60 µm

With optional SuperFlush coating technology



Wedge wire

Material: stainless steel

Filtration rating: 50 µm to 3000 µm

With optional SuperFlush coating technology

Filter elements in SuperMesh.



3-layer sintered wire mesh

Outstanding stability due to sintered element technology

Highly-effective cleaning thanks to optimal velocity distribution in the individual layers of the filter element

It is not possible for particles to build up or lodge between the layers of the filter element

Reliable filtration rating is guaranteed thanks to sintered filter layers and the uniform pore structure

Self-supporting structure: no support tube to reduce the available filtration area

In comparison to conventional wire mesh filter elements with support tube, the available filtration area is significantly larger, by up to 40%



SuperFlush coating technology.



With SuperFlush

Without SuperFlush

A technology unique in filtration: Prevents the build-up and adhesion of sticky particles as well as the formation of biofilm on the filter element surface.

Continuous and thorough filtration.

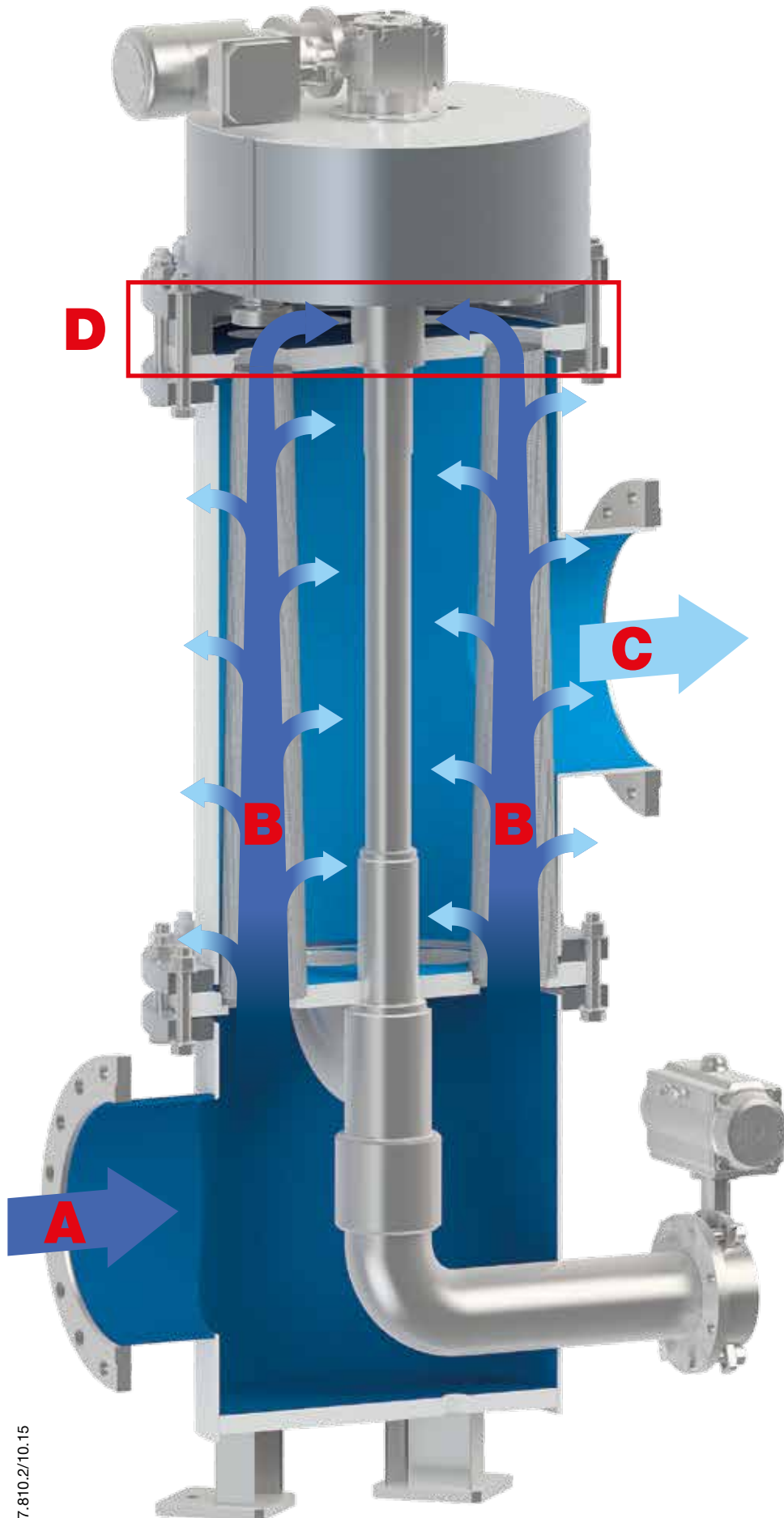

AutoFilt® RF10: Filtration without interrupting production: Consistent performance and cleanliness.

The medium being filtered enters the filter housing via the filter inlet (**A**) and flows through the filter elements of the back-flushing filter from the inside to the outside (**B**) and leaves the filter via the filter outlet (**C**).

During the filtration process, the JetFlush reservoir (**D**) located above the filter elements fills with and stores medium from the contaminated side.

As fluid is filtered, particles collect on the inside of the filter elements.

As the level of contamination increases, the differential pressure between the contaminated and clean side of the filter increases. When the differential pressure reaches the pre-set trigger point, back-flushing starts automatically.

Triggering the back-flushing

Automatic back-flushing is triggered:

- When the differential pressure trigger point is exceeded
- By means of a timer
- By pressing the test button

Back-flushing at low pressures.

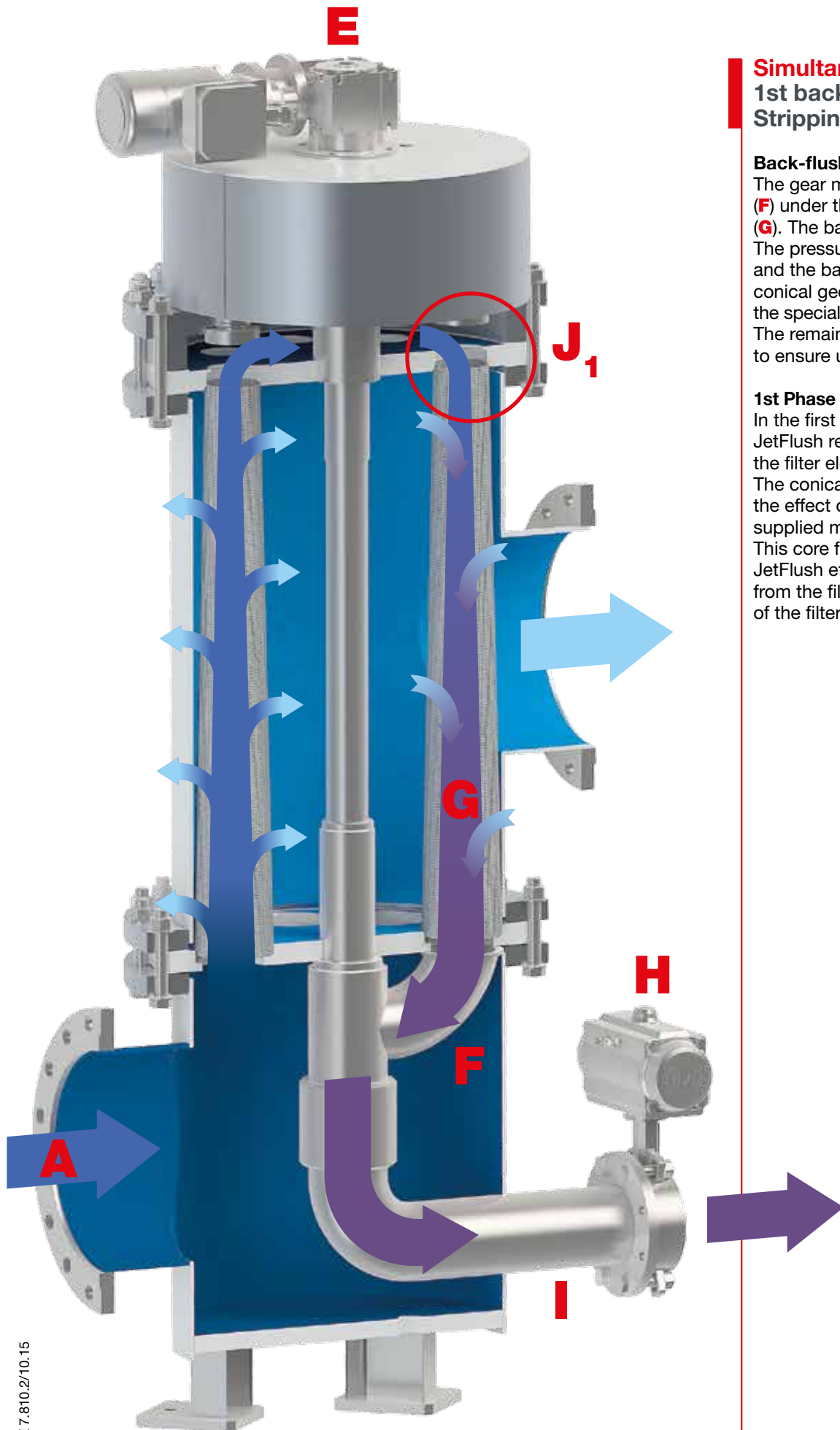

Simultaneously during filtration ...
1st back-flushing phase:
Stripping.

Back-flushing in general

The gear motor (**E**) rotates the back-flush arm (**F**) under the next filter element to be cleaned (**G**). The back-flush valve (**H**) opens. The pressure drop between the filter inlet (**A**) and the back-flush line (**I**), combined with the conical geometry of the element triggers the special JetFlush effect of the AutoFilt® RF10. The remaining filter elements continue filtering to ensure uninterrupted filtration.

1st Phase - Stripping away the contamination

In the first phase, unfiltered fluid from the JetFlush reservoir above (**J₁**) flows into the filter element. The conical filter element geometry has the effect of producing a core flow, supplied mainly by the JetFlush reservoir. This core flow is supported by the open JetFlush effect which also draws water from the filtrate side into the inside of the filter element.

Powerful JetFlush cleaning.

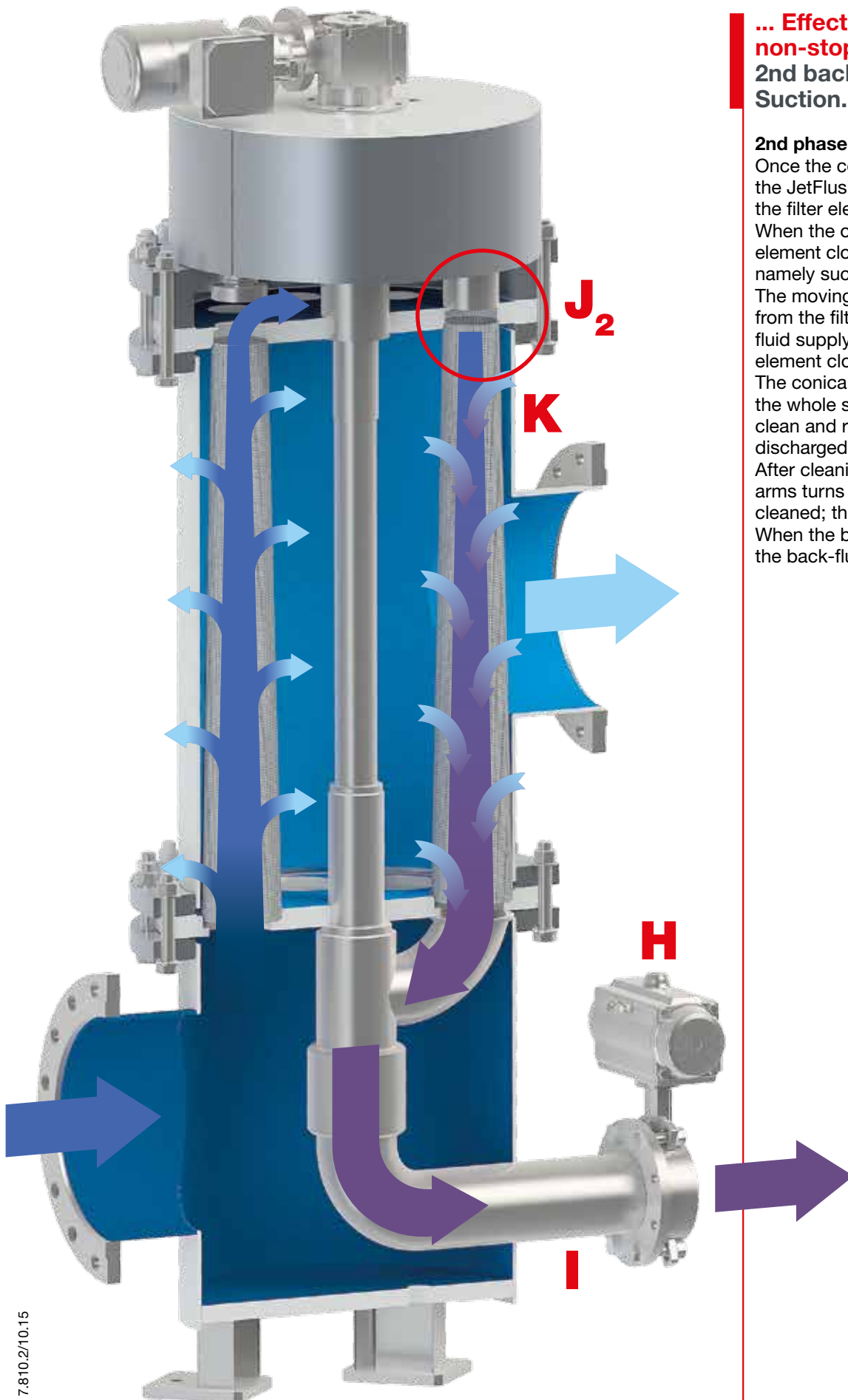

... Effective back-flushing - non-stop:
2nd back-flushing phase: Suction.

2nd phase – Suction

Once the core flow has developed, the JetFlush reservoir (J_2) located above the filter element is closed.

When the opening at the top of the filter element closes, the second phase is initiated, namely suction:

The moving column of fluid draws water from the filtrate side (K) as soon as the fluid supply stops as a result of the filter element closing at the top.

The conical filter element geometry ensures the whole surface of the filter element is now clean and residue-free. The contamination is discharged via the back-flush line (I).

After cleaning the filter element, the flushing arms turns to the next filter element to be cleaned; the process is repeated.

When the back-flush cycle is finished, the back-flush valve is closed (H).

Innovative. Powerful. Efficient.



Easy maintenance.

Low maintenance requirements cut operating costs to a minimum. The optional **Davit** facilitates access to the filter housing.

Individual control parameters.

Control via PLC with LCD display to adjust and read off operating parameters e.g:

- Differential pressure trigger point
- Initiate "Test" cycle
- Timer
- and many more ...

Variable filter isometry.

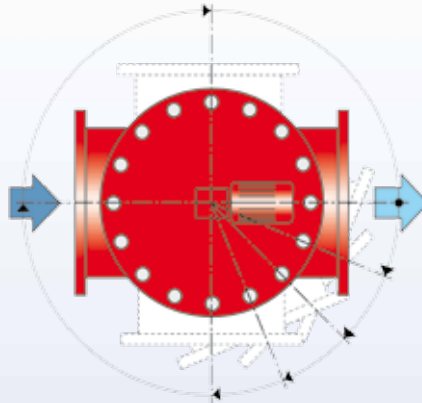

Greatest flexibility is guaranteed when installing the filter into the system because the **flange position can be adjusted** (inlet / outlet / back-flushing line position).

Sacrificial anode.

Optional cathodic corrosion protection provided by an easy-to-install **sacrificial anode**. This protects the internal parts of the filter as well as the filter elements against corrosion, e.g. in sea water applications.

Technical specifications at a glance*

Maximum operating pressure
6 bar

Operating temperature
55 °C

Filtration ratings
25 µm to 3000 µm

Energy supply
Electropneumatic

Material of filter housing
Carbon steel or stainless steel

Material of filter elements
Stainless steel

Material of internal parts
Stainless steel

Corrosion protection for carbon steel filter housing
Polyurethane coating

Filter design



* The information in this brochure relates to the operating conditions and applications described. For applications and / or operating conditions not described, please contact the relevant technical department. Subject to technical modifications.



Accumulators 30,000



Filter Technology 70,000



Process Technology 77,000



Filter Systems 79,000



Compact Hydraulics 53,000



Accessories 61,000



Electronics 180,000



Cooling Systems 5,700

Global Presence. Local Expertise. www.hydac.com



- HYDAC Head Office
- HYDAC Companies
- HYDAC Sales and Service Partners

HYDAC INTERNATIONAL

Head Office
HYDAC PROCESS TECHNOLOGY
GMBH

Industriegebiet Grube König
Am Wrangelflöz 1
66538 Neunkirchen
Germany

Tel.: +49 6897 509-1241
Fax: +49 6897 509-1278

E-Mail: prozess-technik@hydac.com
Internet: www.hydac.com