

X-Series

Directional Control Valve DX-6

Formerly the RSM290 Series



Key valve features

DX-6 is a sectional valve designed for max. operating pressures up to 5000 psi (350 bar) and max. pump flows up to 180 l/min with "Q-inlet". For standard inlets without flow regulator the recommended max. pump flows is 37 gpm (140 Lpm). The valve is available with 1 to 10 working sections per valve assembly.

DX-6 includes as standard a variety of sections, spools, spool controls and additional parts in a modular design. That makes the valve very flexible.

The valve is, as standard, setup for both manual and remote control. The manual controlled sections can either be with open spool ends or encapsulated. The encapsulation decreases in a significant way the risk for external leakage and makes the valve well adapted for applications in demanding environment. The spool controls for remote control are generally designed as complete modules for assembling on one of the valve sides.

DX-6 is in first place designed as an open center valve for fixed displacement pumps but can also be configured for variable displacement pumps. It is available with manual, hydraulic or electro hydraulic proportional remote control.

DX-6 can be fully adapted for marine applications. The valve offers excellent operating characteristics, and good controllability on a wide range of machinery due to the specially designed spools. Low and uniform spool forces are the result of careful balancing of the flow forces.

Q-inlet

The Q-inlet is designed with a flow control (Q-function) that by-passes the major part of the pump flow to tank when the system is idling, still giving access to full pump flow when the working sections are operated. Besides greatly reducing heat generation this also provides improved operating characteristics.

Applications

The DX-6 is ideal for applications where you need excellent control characteristics such as cranes, sky-lifts, garbage

Technical data

Pressures / Flows

Max. operating pressure set per port:

| | | |
|-------------|----------|---------|
| P1, P2, PM: | 5000 psi | 350 bar |
| A, B: | 5800 psi | 400 bar |
| T1, T2, T3: | 300 psi | 20 bar |
| Pp: | 450 psi | 30 bar |
| Tp: | 75 psi | 5 bar |
| X, Y: | 360 psi | 25 bar |

Typical Nominal Inlet Flow:

| | | |
|-------------------------------------|------------------|-------------------|
| Inlet without flow control function | 37 gpm | 140 Lpm |
| Inlet with flow control function | 48 gpm | 180 Lpm |
| Fluid temperature range | 5°F up to +176°F | -15°C up to +80°C |

Further data

| | | |
|--|----------|-------|
| Spool stroke nominal: | ±0.27 in | ±7 mm |
| Spool control force spool control 9M1: | | |
| Neutral position: | 20 lb. | 90 N |
| Max. spool stroke: | 24 lb. | 105 N |

Permissible contamination level:

| |
|--|
| Spool control M: Equal or better than 20/18/14 as per ISO 4406 |
| Spool control H, EH: Equal or better than 20/17/13 as per ISO 4406 |

Viscosity range: 10 – 400 mm²/s (cSt); Higher viscosity allowed at start up.

Leakage at 1450 psi, 32 cSt, 100° F ≤ 12 cc/min (100 bar, 32 cSt and 40°C)

Pressure fluid: Mineral oil and syntetic oil based on mineral oil HL, HLP according to DIN 51524.

Higher values are possible, depending on application. For applications with demands that exceed stated data above, please contact us for consideration.

MTTFd value after consultation with HYDAC.

trucks, demountable bodies, excavators, telescopic load handlers, skid-loaders, wheel loaders etc.

Remote control

As remote controlled the valve offers compact design with internal pilot oil supply, solenoids in a compact assembly on one side of the valve and integrated hand levers for manual override/manual operation. The integrated pilot supply system for the electro hydraulic remote control makes the valve easy to install and gives a reliable remote control function. It is also possible to

supply the pilot system externally. The hydraulic remote control can also be configured both for internal and external pilot supply.

Accessories

- A wide choice of spools and spool controls for different flow combinations and for several applications and systems
- A full range of service port valves
- Possibility of high pressure carry-over
- Inlet with electrical unloading valve
- Manual versions easily convertible to remote control

General overview

The drawing shows a 4-sectional valve with inlet and outlet. The sections are with various types of spool controls. SAE ports are shown in the table.

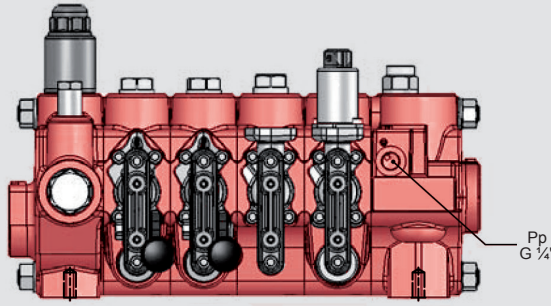

Port Sizes for US Models

| | | | |
|-----|-------|----|-------|
| P1 | SAE12 | P2 | SAE12 |
| T1 | SAE16 | T2 | SAE20 |
| T3 | SAE16 | T4 | SAE16 |
| A&B | SAE12 | | |
| X | SAE04 | Y | SAE04 |
| Pp | SAE06 | Tp | SAE06 |
| PM1 | SAE04 | | |

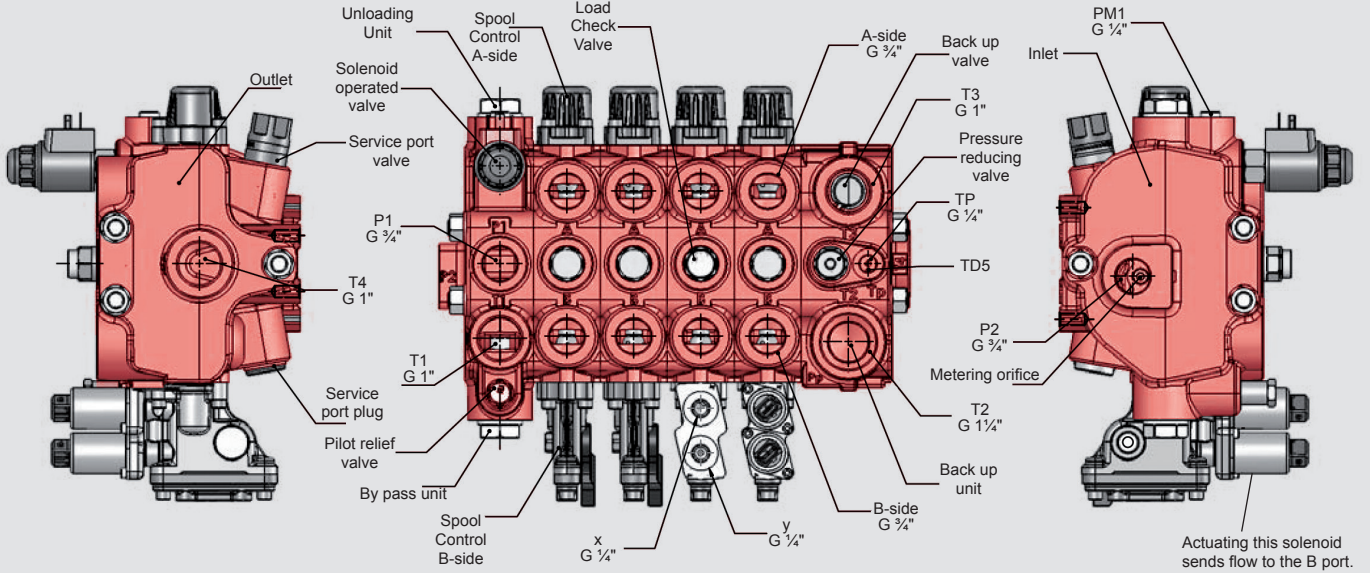

Pressure drop Oil temperature/viscosity for all graphs: +40°C / 32 cSt

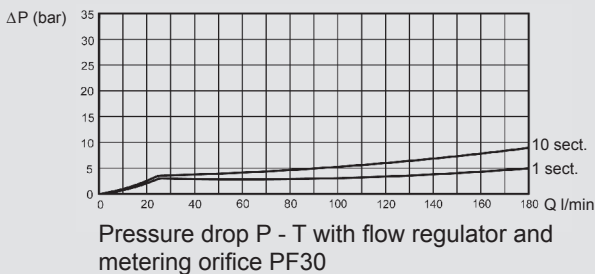
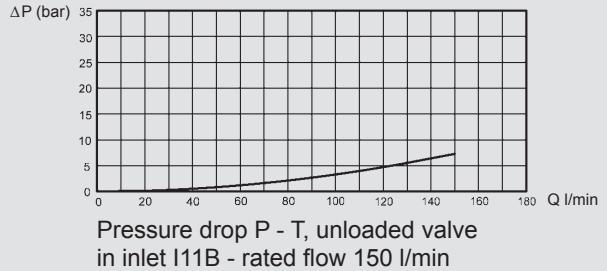
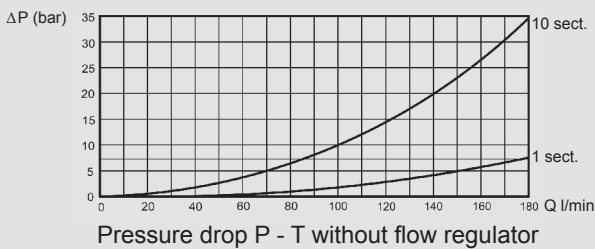
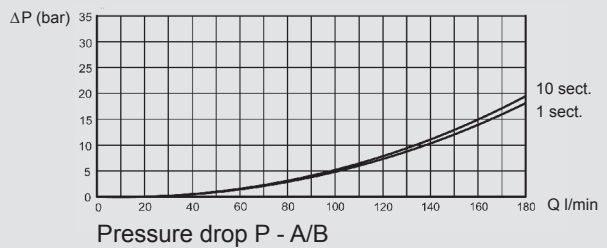
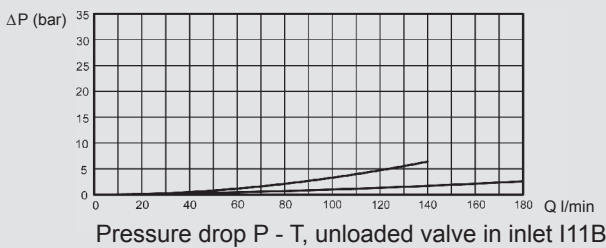
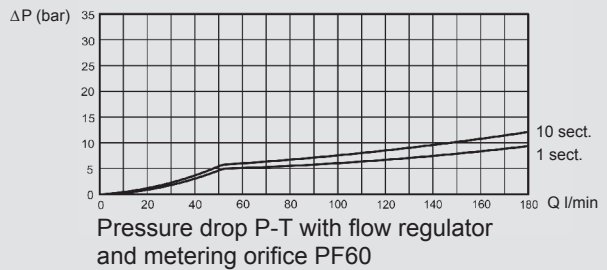
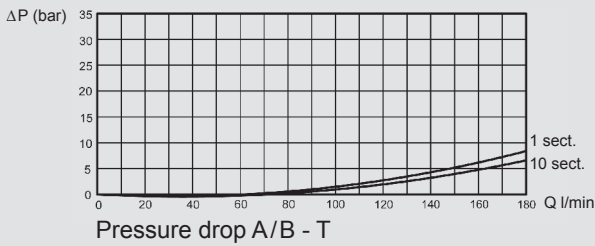

Note: The pressure drop curves are valid for sections equipped with spools that are fully open at maximum spool travel.

Dimensions and weight

The drawing shows a 4-section valve with standard inlet section, working sections manual operated and a multisection/outlet.

SAE ports are shown in the table.

Port Sizes for US Models

| | | | |
|-----|-------|----|-------|
| P1 | SAE12 | P2 | SAE12 |
| T1 | SAE16 | T3 | SAE16 |
| A&B | SAE12 | | |
| PM1 | SAE04 | | |

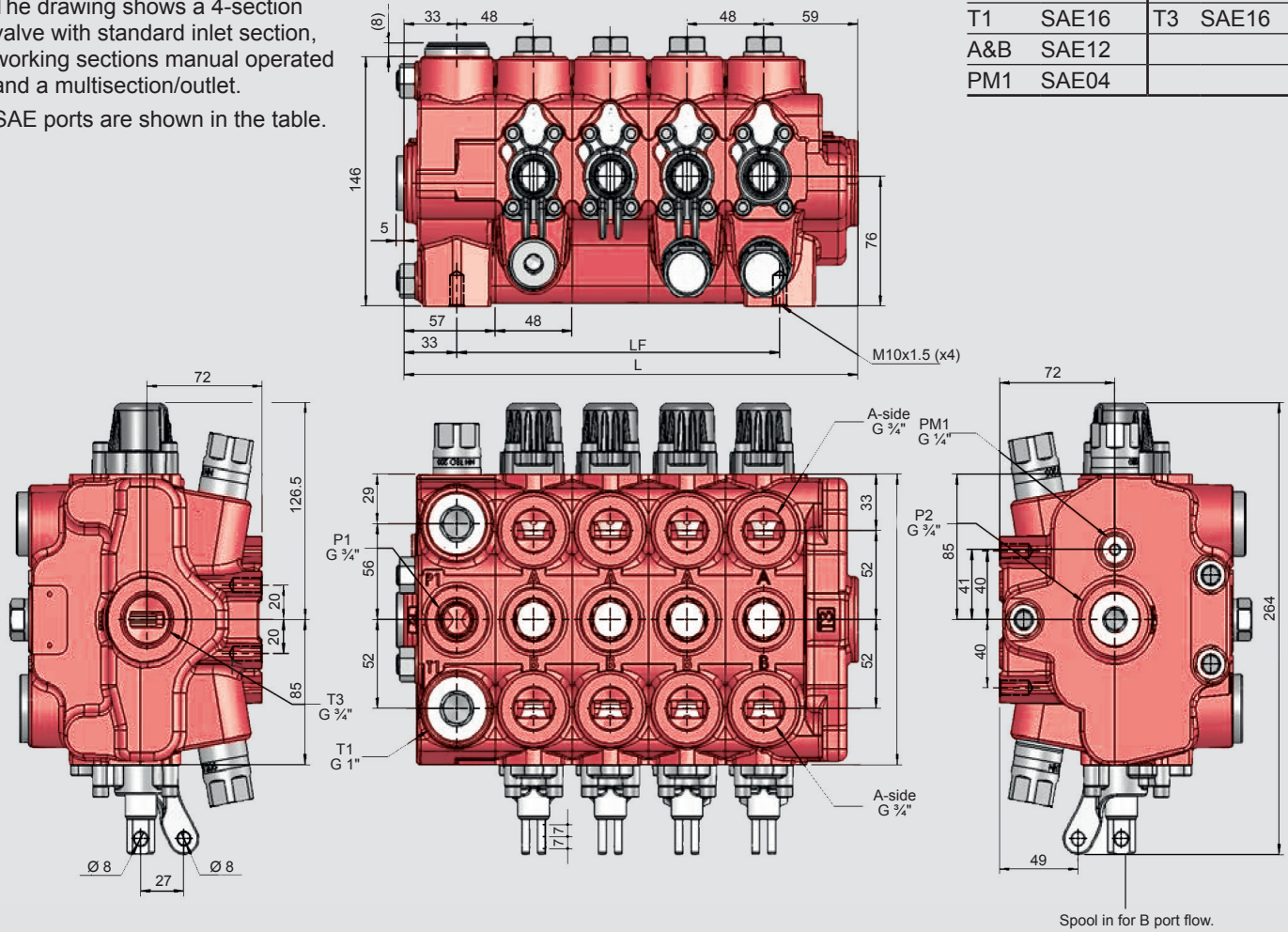

| No. of working sections | L (in) | L (mm) | LF (in) | LF (mm) |
|-------------------------|--------|--------|---------|---------|
| 1 | 5.5 | 140 | 2.3 | 58 |
| 2 | 7.4 | 188 | 4.2 | 106 |
| 3 | 9.3 | 236 | 6.1 | 154 |
| 4 | 11.2 | 284 | 8.0 | 202 |
| 5 | 13.1 | 332 | 9.8 | 250 |
| 6 | 15.0 | 380 | 11.7 | 298 |
| 7 | 16.9 | 428 | 13.6 | 346 |
| 8 | 18.7 | 476 | 15.5 | 394 |
| 9 | 20.6 | 524 | 17.4 | 442 |
| 10 | 22.5 | 572 | 19.3 | 490 |

Inlet Section I23B

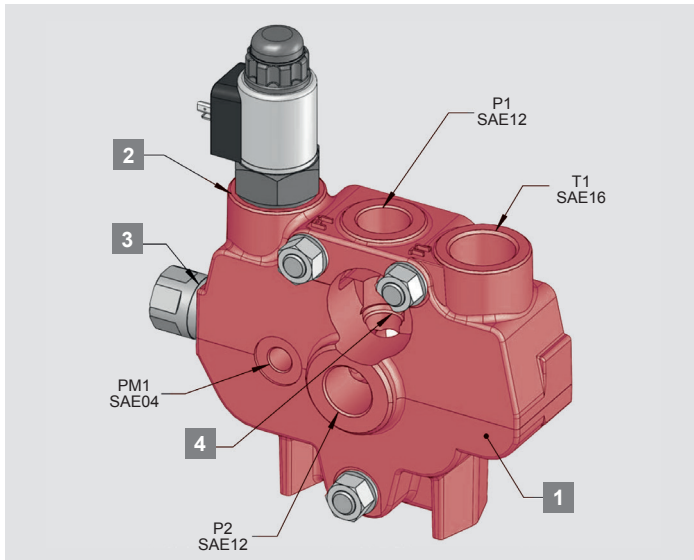

The standard inlet section I23B has two pump connections P1 and P2, a gauge port PM1 to monitor system pressure and a tank connection T1. Direct acting main relief valve (TBD201), and an unloading function via 2/2 solenoid valve (EU) for emergency dump of pump flow. The cavity (4) can be used to separate the parallel gallery from the center gallery to accomplish systems with parallel connection downstream of another valve or to control a variable pump.

Main relief function

TBD201 is adjustable and sealable for setting range 580 - 4,500 psi (40 - 300 bar) with setting step 100 psi (7 bar).

Unloading valve EU12 and EU24

EU12 and EU24 are 2-way, normally open, solenoid type cartridge valves. It is an option in all inlet sections.

It is intended for emergency stop and for pressure drop/heat generation reduction.

| | |
|------------------------|--------------------------------------|
| Rated flow: | 40 gpm, 4,000 psi (150 Lpm, 280 bar) |
| Rated flow: | 27 gpm, 5,000 psi (100 Lpm, 350 bar) |
| Power consumption: | 18 W |
| Rated voltage EU12: | 12 V |
| Rated voltage EU24: | 24 V |
| Max voltage variation: | +/-15% |
| Duty factor*: | 100% |
| Connection: | EN 175301-803 form A |
| Protection class: | IP65 |

* Sufficient cooling must be secured.

The unloading valve has manual override, with twist pin operation. PE21 is the plug for the cavity.

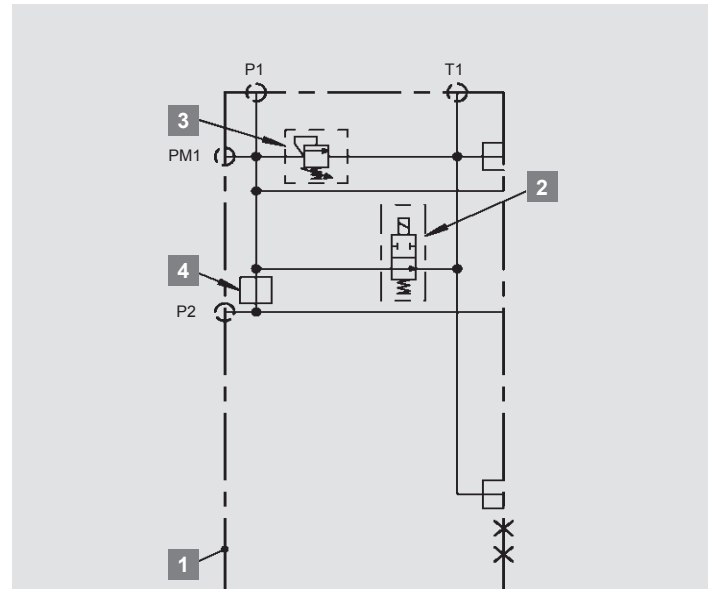

| | | |
|---|----------------------|--------|
| 1 | Inlet | I23B |
| 2 | Unloading valve | EU24 |
| 3 | Relief valve | TBD201 |
| 4 | Cavity for plug PM02 | N/A |

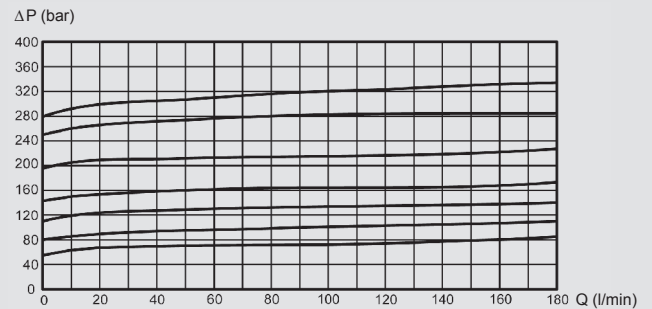

Characteristic main relief function (TBD201)

Inlet section I13B

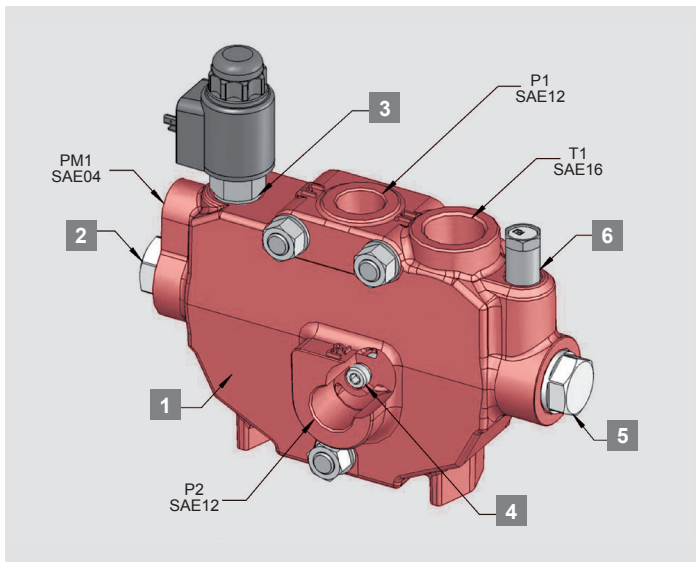

Flow control function

The inlet section I13B with its integral Q-function provides by-pass of pump flow to tank in idling condition, thereby reducing pressure drop and heat generation. It also reduces flow forces and makes the control response to large extent unaffected by varying pump flows. This contributes to the excellent operating characteristics achievable with DX-6.

The regulated flow into the centre passage is set by an exchangeable metering orifice (4).

In case the I13B inlet section is configured with metering orifice PF60, this orifice determines the high pressure carry over flow to downstream arrangements.

Unloading function

An unloading spool along with an electrical operated pilot valve forms the unloading function. The unloading spool both unloads the pump flow to tank and as well disconnects the valve's parallel passage from the pump.

Together with a load holding valve, DX-6 achieves a very safe emergency dump of pump flow to tank.

EU912 and EU926 are 2-way, normally open, solenoid type cartridge valves. It is an option in all inlet sections. It is intended for emergency stop and for pressure drop/heat generation reduction.

| | |
|------------------------|----------------------|
| Rated flow: | 11 gpm (40 Lpm) |
| Power consumption: | 18 W |
| Rated voltage EU12: | 12 V |
| Rated voltage EU24: | 24 V |
| Max voltage variation: | +/-15% |
| Duty factor*: | 100% |
| Connection: | EN 175301-803 form A |
| Protection class: | IP65 |

* Sufficient cooling must be secured.

The unloading valve has manual override, with twist pin operation. PE20 is the plug for the cavity.

Main relief function

The by pass unit FK29 in combination with the relief valve TB 12 form the pilot operated relief valve function.

TB12 is adjustable and sealable for setting range 200-5000 psi (40 – 350 bar) with setting step 100 psi (7 bar).

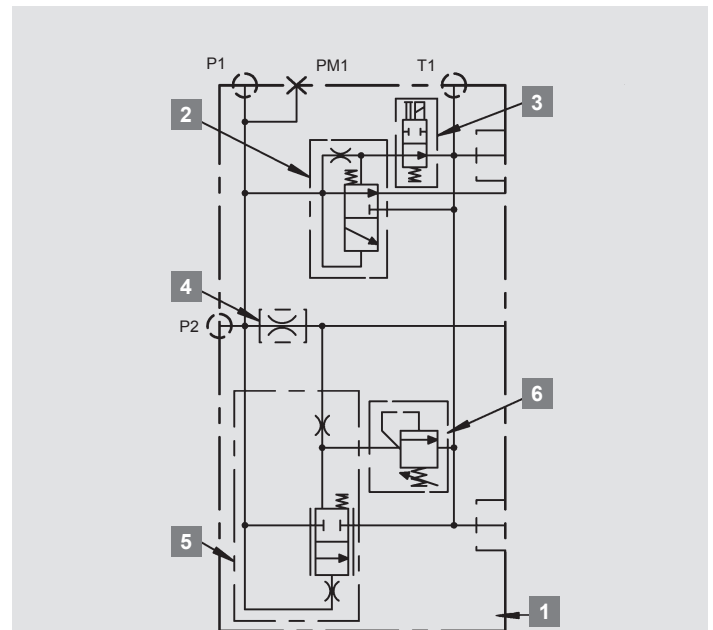

| | | |
|---|--|------|
| 1 | Inlet section | I13B |
| 2 | Unloading unit | FU29 |
| 3 | Solenoid operated valve | E926 |
| 4 | Metering orifice for centre channel flow | PF60 |
| 5 | By-pass flow control unit | FK29 |
| 6 | Pilot relief valve | TB12 |

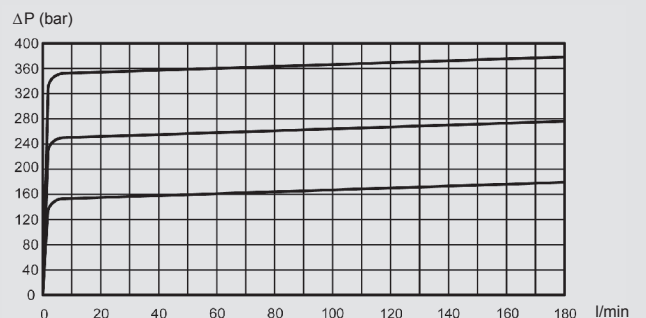

Characteristics main relief function

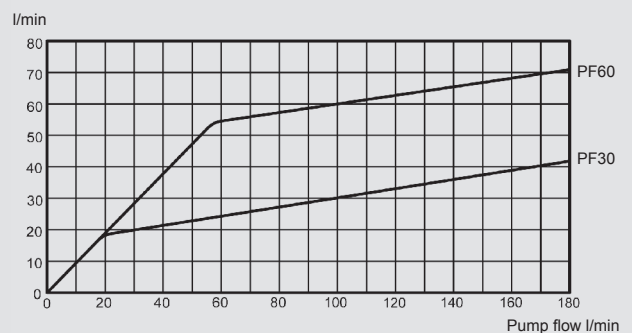

Characteristics regulated flow

Oil temperature / viscosity for all graphs: 104°F (+40°C)

Working section S14L

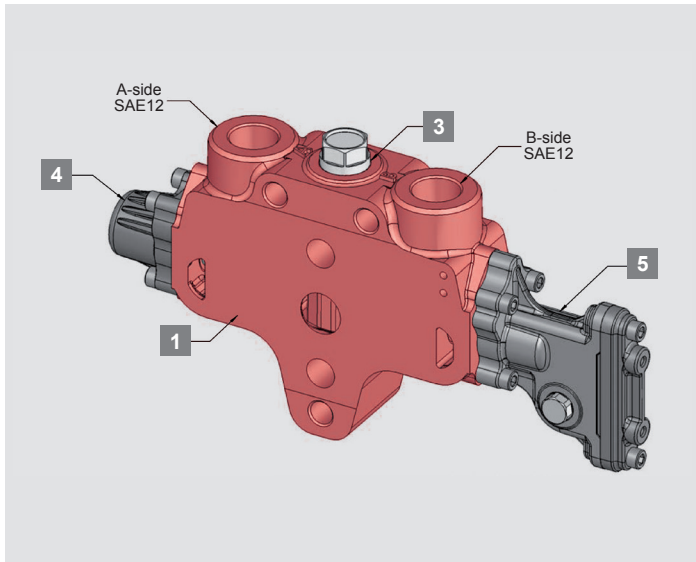

Working section S14L for both manual and remote operation. The example shows a section configured for manual operation with the spring centering spool control on A-side and encapsulated lever mechanism on B-side spool actuator. The section S14L includes a loadcheck valve.

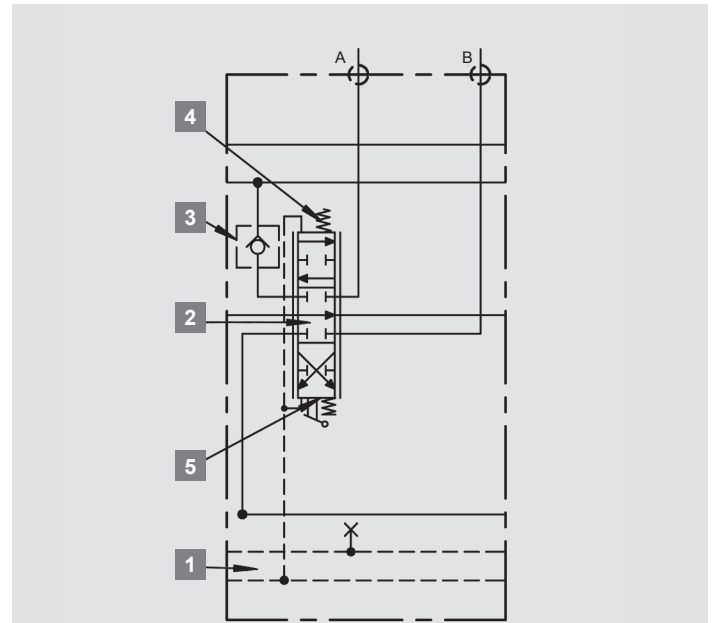

| | | |
|---|------------------------|------|
| 1 | Working section | S14L |
| 2 | Spool | 1XY |
| 3 | Load check valve | MF29 |
| 4 | Spool control, A-side | 9M1 |
| 5 | Spool actuator, B-side | M1 |

Working section S24L

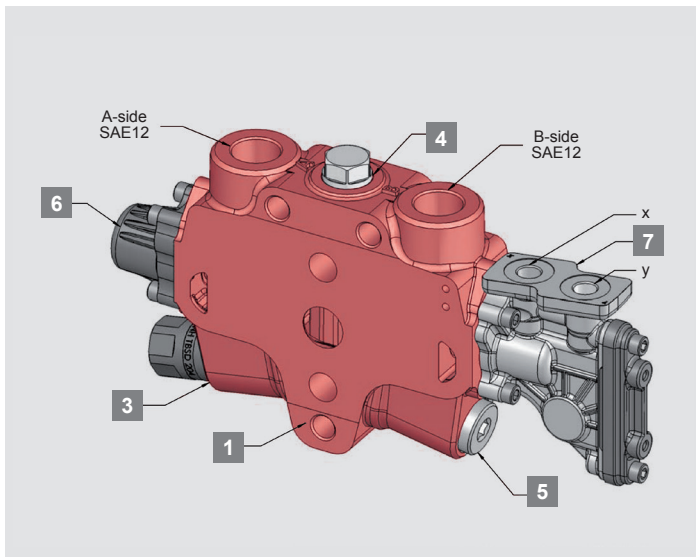

Working section S24L for both manual and remote operation. The example shows a section configured for hydraulic remote control with the spring centering spool control on A-side and the ports for control pressure on the B-side spool actuator. The section S24L includes loadcheck valve and cavities for service port valves of type TBD/TBSD205.

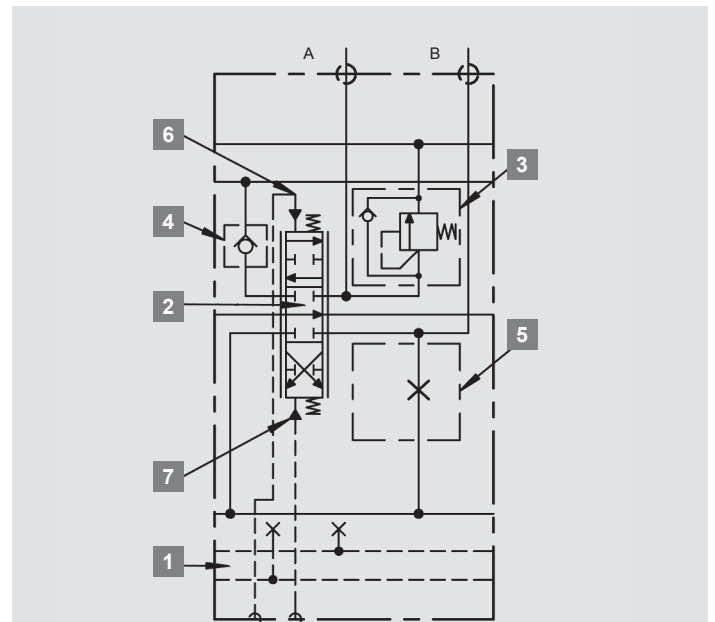

| | | |
|---|------------------------|--------|
| 1 | Section | S24L |
| 2 | Spool | 1XY |
| 3 | Service port valve | TSD205 |
| 4 | Load check valve | MB29 |
| 5 | Service port plug | P204 |
| 6 | Spool control, A-side | 9R1 |
| 7 | Spool actuator, B-side | H1 |

Work section S34L

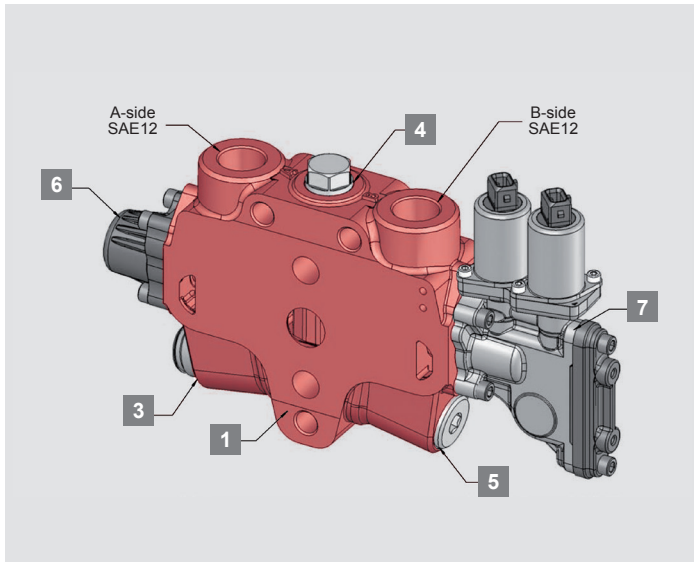

Working section S34L for both manual and remote operation. The example shows a section configured for electro hydraulic remote control with the spring centering spool control on A-side and the proportional solenoids on the B-side.

The section S34L includes loadcheck valve and cavities for service port valves of type TBSD280.

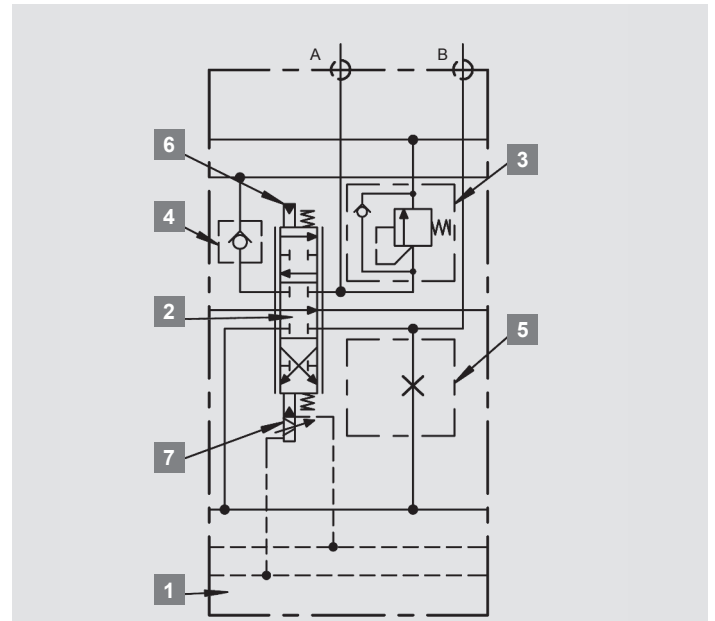

| | | |
|---|-----------------------|---------|
| 1 | Section | S34L |
| 2 | Spool | 1XY |
| 3 | Service port valve | TBSD280 |
| 4 | Load check valve | MB29 |
| 5 | Service port plug | P280 |
| 6 | Spool control, A-side | 9R1 |
| 7 | Spool control, B-side | EH1XX |

Load check valve

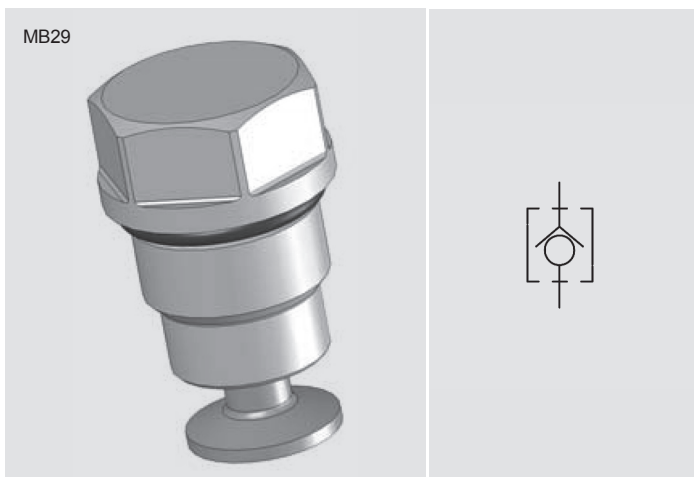
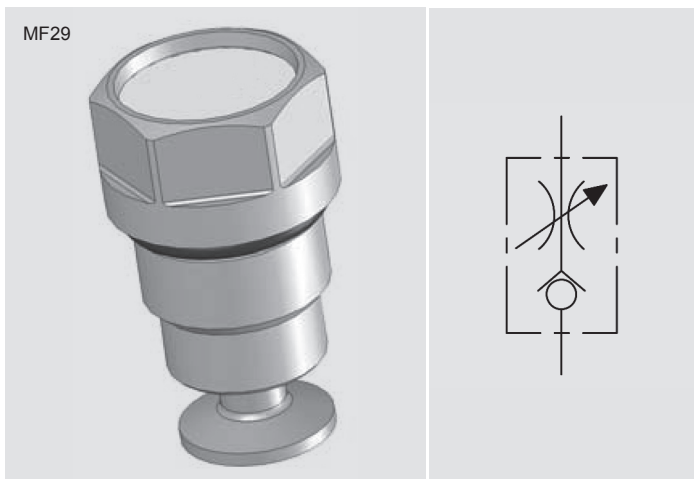

The main function of the load check valve is to prevent the load from moving backwards if the load pressure is higher than pump pressure when operating.

MB29
Load check valve.

MF29
Load check valve with adjustable flow limitation. MF29 restricts the flow out from a section. Typical application is a slewing function.

Outlet section U13B

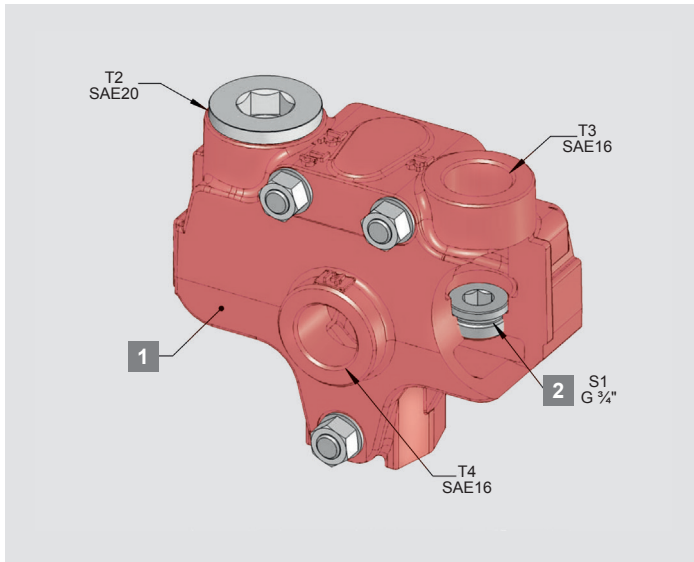

The standard outlet section U13B has three tank connection ports T2, T3 and T4.

Port T3 is used for high pressure carry over function (HPCO) when plug S29 is installed in the S1 cavity (see example).

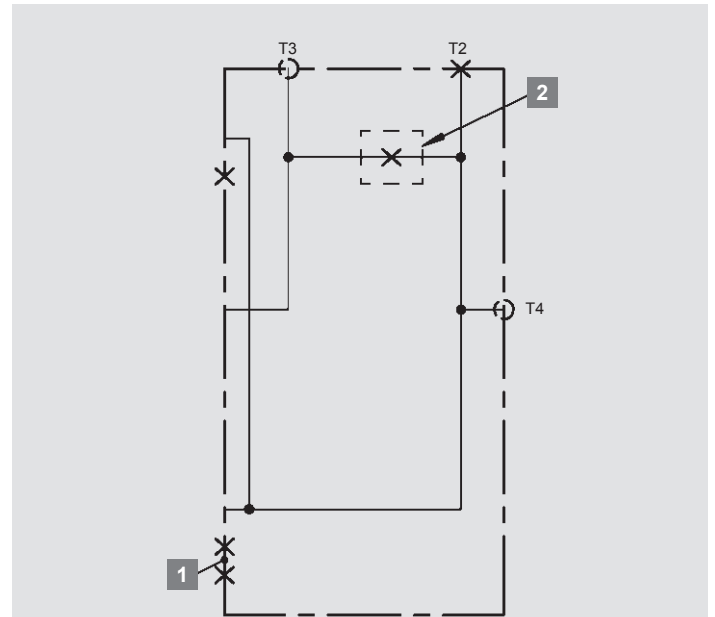

| | | |
|---|--------------------|------|
| 1 | Outlet selection | U13B |
| 2 | S1 Carry over plug | S29 |

Outlet section U13L

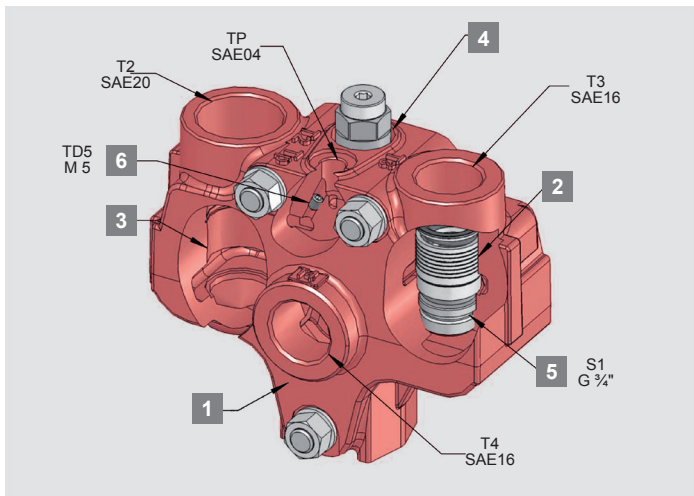

The outlet section U13L with integrated pilot pressure supply for a valve with electro-hydraulic remote controlled working sections. Same configuration can be used for pilot pressure supply, via port Pp, to a hydraulic controller for use with hydraulic remote controlled working sections.

To ensure sufficient pressure for the pilot circuit a start up pressure is generated by the back-up cartridge BUP14 installed in cavity 2. The back-up cartridge can be used in combination with HPCO plug S29. A pressure reducing valve TRA63 limits the pressure in the pilot circuit.

Because the pilot pressure is supplied from the parallel gallery an emergency stop will also unload the pilot pressure.

It is recommended to drain the return flow in the pilot circuit via port Tp direct to tank in separate piping. This is accomplished by PMS5 installed in cavity 6. Note: The port Tp must not be plugged when PMS5 is installed.

The outlet section U13L can be configured with a back-up cartridge (BUP14 installed in cavity 3) for an increased pressure in the return passage to prevent cavitation in severe conditions. This is accomplished without compromising the pressure drop P – T at idling.

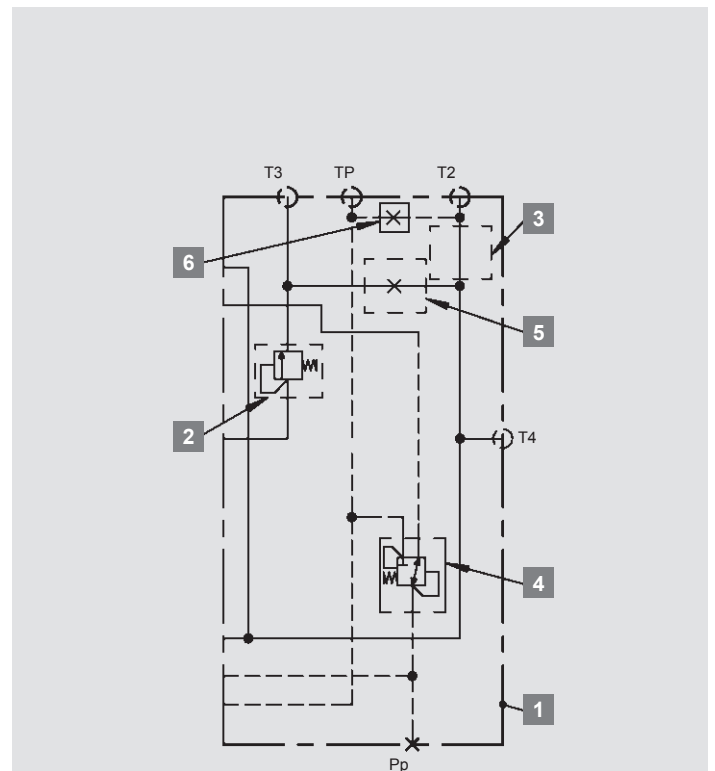

| | | |
|---|---------------------------------|-----------|
| 1 | Outlet selection | U13L |
| 2 | Back up valve | BUP14 |
| 3 | Pilot pressure valve | BUP14 |
| 4 | Pressure reducing valve or plug | TRA63/P63 |
| 5 | Carry over plug | S29 |
| 6 | Plug for pilot drain | PMS5 |

Outlet with working section US24L

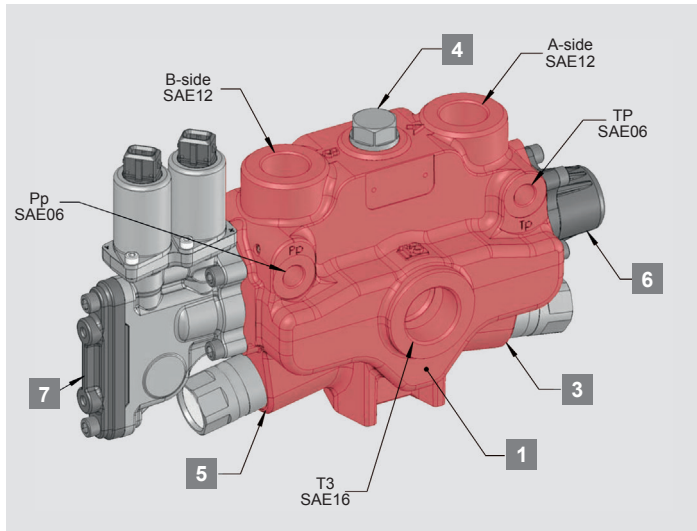

The US24L is an outlet section with integrated spool section, T3 port for tank connection for both manual operation and remote control with external pilot pressure supply. High pressure carry over function is achieved with SU31 installed in port T3. Pp – supplied pilot pressure, Tp – pilot drain.

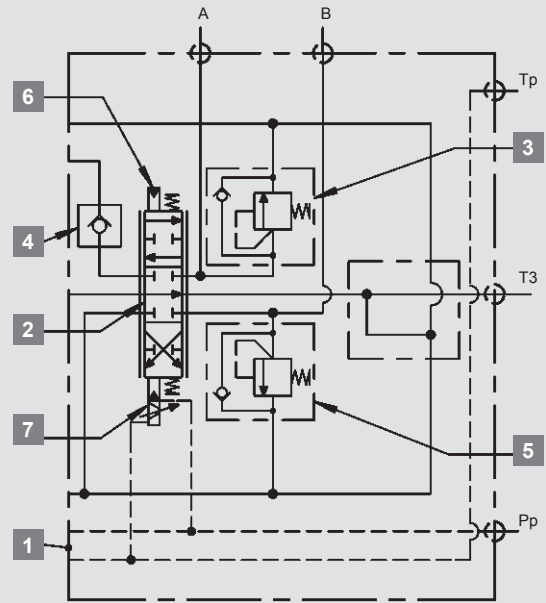

| | | |
|---|----------------------------|---------|
| 1 | Outlet and working section | US24L |
| 2 | Spool | 1XY |
| 3 | Service port valve | TBSD205 |
| 4 | Load check valve | MB29 |
| 5 | Service port plug | TBSD205 |
| 6 | Spool control A-side | 9R1 |
| 7 | Spool actuator B-side | EH1XX |

Mid outlet N13B

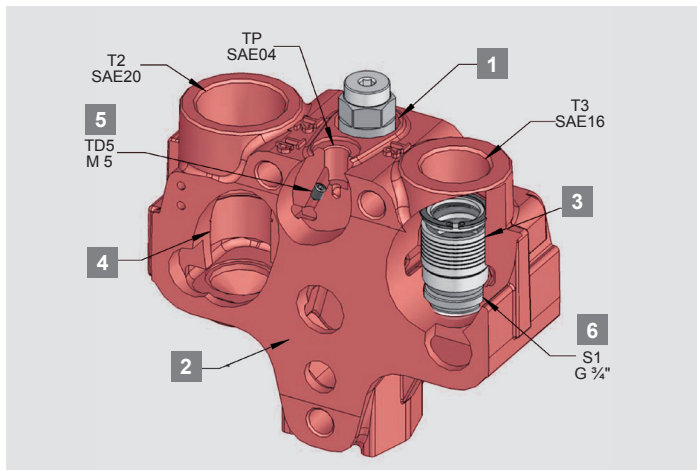

The mid-outlet section N13B with integrated pilot pressure supply for a valve with electro-hydraulic remote controlled working sections. Same configuration can be used for pilot pressure supply, via port Pp, to a hydraulic controller for use with hydraulic remote controlled working sections.

To ensure sufficient pressure for the pilot circuit a start up pressure is generated upstream of the mid-outlet by the back-up cartridge BUP14 installed in cavity 3. The back-up cartridge can be used in combination with HPCO plug S29. A pressure reducing valve TRA63 limits the pressure in the pilot circuit.

Because the pilot pressure is supplied from the parallel gallery an emergency stop will also unload the pilot pressure.

It is recommended to drain the return flow in the pilot circuit via port Tp direct to tank in separate piping. This is accomplished by PMS5 installed in cavity 5. Note: The port Tp must not be plugged when PMS5 is installed.

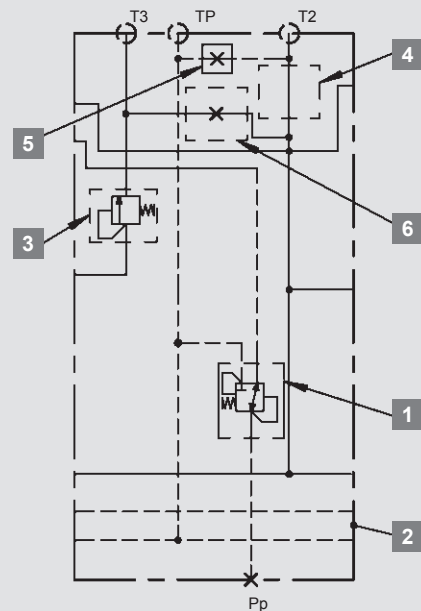



| | | |
|---|-------------------------|-------|
| 1 | Pressure reducing valve | TRA63 |
| 2 | Mid outlet section | N13B |
| 3 | Back up valve | BUP14 |
| 4 | Pilot pressure valve | BUP14 |
| 5 | Plug for pilot drain | PMS5 |
| 6 | Carry over plug | S29 |

The mid-outlet section N13B can be configured with a back-up cartridge (BUP14 installed in cavity 4) for an increased pressure in the return passage to prevent cavitation in severe conditions. This is accomplished without compromising the pressure drop P – T at idling.

Spool controls A-side

The spool controls are designed in a modular system for a high degree of flexibility. The sections are basically symmetric but as standard machined either for left or right hand inlet with spool actuator on B-side and spool control on A-side.

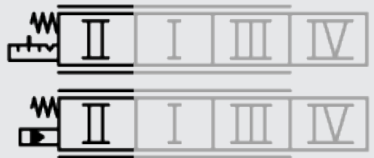
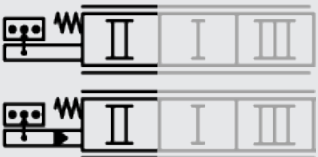
| | |
|--|---|
| |  |
| Spool control 9 9M1 Manual spring centered 3 pos. encapsulated. 9MO1 Manual spring centered 3 pos. open spool ends. 9R1 Remote spring centered 3 pos. |  |
| Spool control 11 11M1 Manual spring centered 4 pos. encapsulated. 11MO1 Manual spring centered 4 pos. open spool ends. 11R1 Remote spring centered 4 pos. |  |
| Spool control S* SM11 Manual spring centered 3 pos. spool position indicator. SMO11 Manual spring centered 3 pos. open spool ends spool position indicator. SR11 Remote spring centered 3 pos. spool position indicator. |  |

Spool controls B-side

Remote spool actuators can be with or without manual override. The valve is, as standard setup for both manual and remote control.

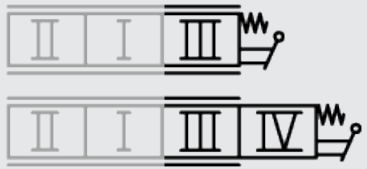
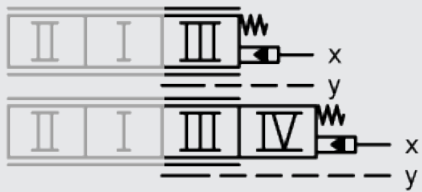
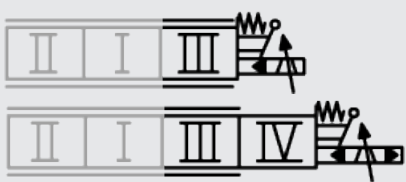
| | |
|--|--|
| |  |
| Spool actuator/bracket M M1 for manual lever 3 pos. MO3 for manual lever 3 pos. open spool ends. MO3F for manual lever 4 pos. open spool ends. |  |
| Spool actuator H H1 Hydraulically 3 pos. manual override available as option (H1M1). H1F Hydraulically 4 pos. Manual override available as option (H1M1F). |  |
| Spool actuator EHM EHM1** Electro hydraulically manual override 3 pos. Without manual override as option (EH1**). EHM**F Electro hydraulically manual override 4 pos. without manual override as option (EH1**F). |  |

* standard connector M12x1, also available in Deutsch connector.

** 12 or 24 V DC.

Solenoid valve for EHP – ER12 / 24

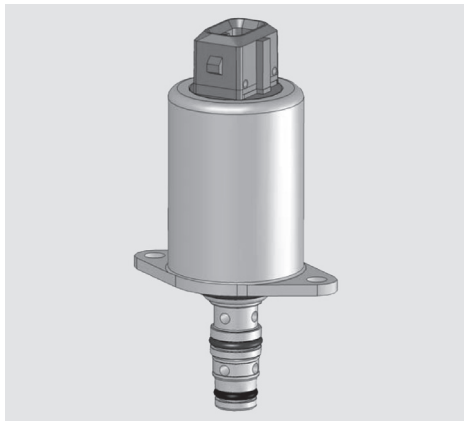

The solenoid valves are 3/2-way electrically operated pressure reducing valves used to provide controlled pilot pressure to operate valve spools.

| | |
|----------------------------|------------------------------|
| Functional principle: | PWM (Pulse Width Modulation) |
| Duty factor: | 100 % |
| Connection: | DEUTSCH DT04* |
| Recommended PMW frequency: | 100 Hz |
| Protection class: | IP 65 |
| Ambient temperature: | -30 °C up to +80 °C |

ER12

| | |
|-------------------------|----------|
| Rated voltage: | 12 V DC |
| Starting current: | 600 mA |
| Fully shifted: | 1,500 mA |
| Coil resistance +20 °C: | 4.72 Ohm |

ER24

| | |
|-------------------------|----------|
| Rated voltage: | 24 V DC |
| Starting current: | 300 mA |
| Fully shifted: | 750 mA |
| Coil resistance +20 °C: | 20.8 Ohm |

*Also available with AMP Junior-Power-Timer

Levers

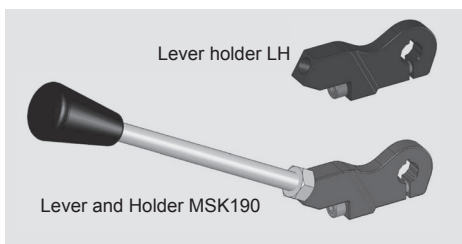

Lever and Holder MSK190

The lever holder (LH) is for use together with spool actuator of type M1/EHM.

The lever holder is delivered in combination with a lever as MSK190.

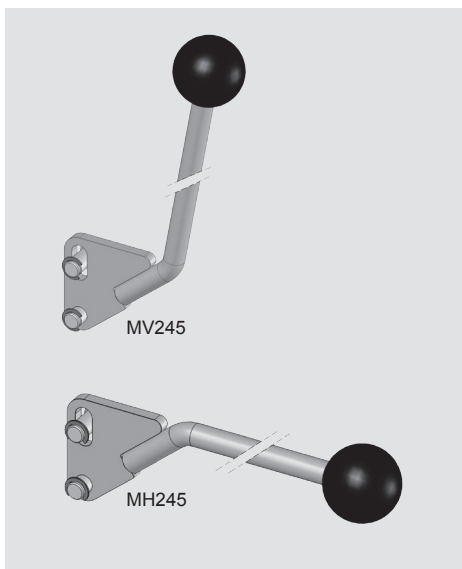

Lever MV/MH

Lever for use in combination with open spool ends and a bracket M03/M03F. When mounted on a valve, the lever MH stands in a horizontal position and MV stands in a vertical position. Lever length 145 or 245 mm.

Spools – main design parameters

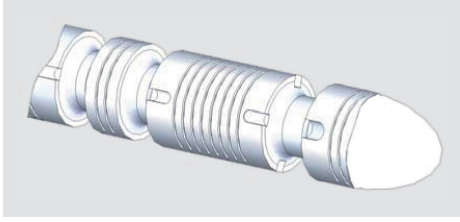

Generally the spools are divided in 3 different flow ranges.
 The position indicating **regulated** flow ranges is replaced by X.
 The position indicating **pump** flow is replaced by Y.
 The last three positions in the code are design parameters.
 In the table only the accessibility of different functions are shown.

Pos. 1 – Functionality

| Diagram | Function | Code |
|---------|-----------------------------------|------|
| | Spools for general use | |
| | | |
| | Double acting | 1XY |
| | Single acting | 2XY |
| | Double acting, 4th pos. for float | 3XY |
| | Motor spool A – T | 4XY |
| | Regenerative | 8XY |

Pos. 2 – Regulated center flow – X in the code above

0 = Full pump flow i. e. no regulated flow

3 = 7.5 gpm (30 Lpm) regulated flow (use with inlet section I13B)

6 = 15 gpm (60 Lpm) regulated flow (use with inlet section I13B)

Pos. 3 – Pump flow supplied – Y in the code above

3 = 20 gpm ± 2.5 gpm (80 Lpm ± 10 Lpm)

4 = 30 gpm ± 5 gpm (110 Lpm ± 20 Lpm)

6 = 160 l/min +/- w30 l/min

Example:

Spool 136xxx – double acting spool with 7.5 gpm regulated flow and 40 gpm pump flow, xxx in the code are design parameter.

The DX-6 spools are available in a variety of flows and styles to accommodate most design requirements. Since the development of spools is a continuous process and all available spools are not described in this data sheet, contact HYDAC for advice on choosing spools in order to optimize your valve configuration.

Service port valves

Port relief valve TBD205

TBD205 is a differential area, direct acting relief valve, for the secondary circuit. It is adjustable and sealable.

Setting range for TBD205:

- 600-4,350 psi (40-300 bar)
- Setting range step: 100 psi (7 bar)

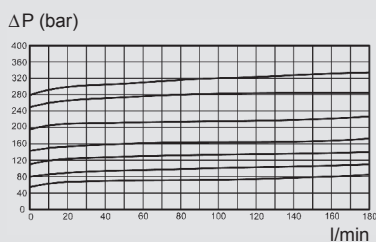

Relief characteristics TBD205

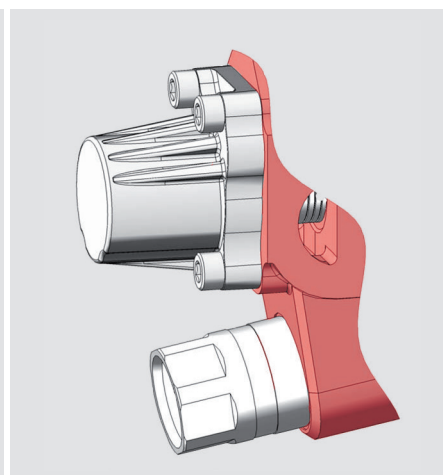
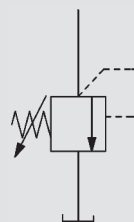

Port relief valve TBSD205

TBSD205 is a differential area, direct acting relief and anticavitation valve, for the secondary circuit. It is adjustable and sealable.

Setting ranges for TBSD205:

- 600-4,350 psi (40-300 bar)
- Setting range step: 100 psi (7 bar)

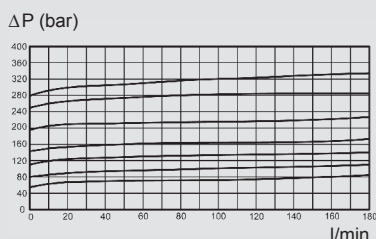

Relief characteristics TBSD205

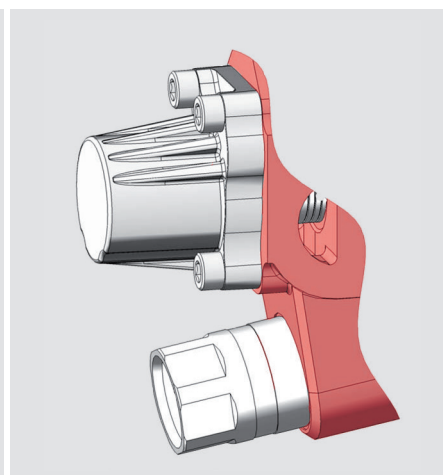
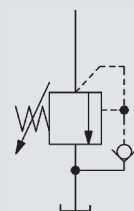

Port relief and anticavitation valve TBSD280

TBSD280 is a direct acting relief and anticavitation valve, for the secondary circuit. It is fixed and sealable.

Setting ranges for TBSD280:

- 1,300-5,800 psi (90-400 bar)
- Setting range step: 100 psi (7 bar)

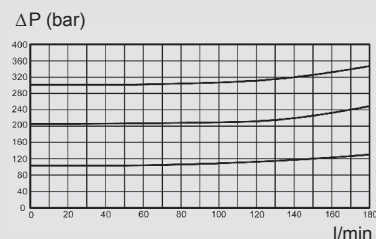

Relief characteristics TBSD280

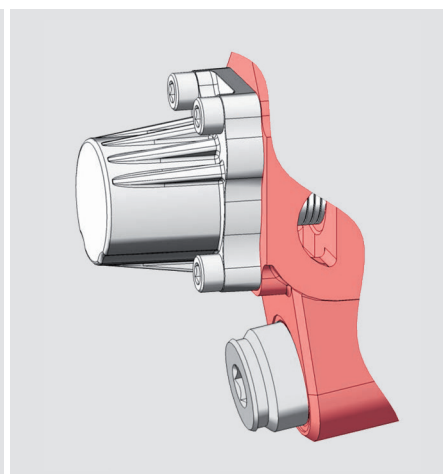
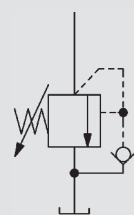

Anticavitation valve SB204

The anticavitation valve service to ensure that, in the event of a lower pressure in the cylinder port than in the tank, oil can be drawn from the system oil tank to the consumer.

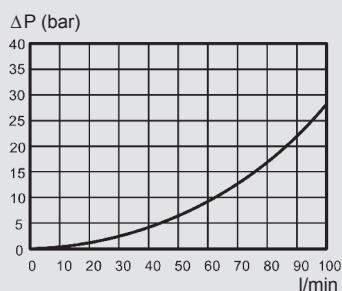

Anticavitation characteristics
TBSD205 and SB204

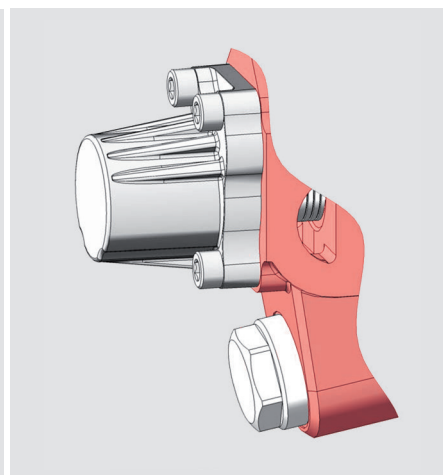
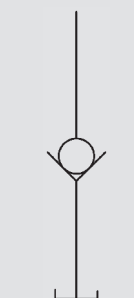

Service port valves

Anticavitation valve SB280

The anticavitation valve service to ensure that, in the event of a lower pressure in the cylinder port than in the tank, oil can be drawn from the system oil tank to the consumer.

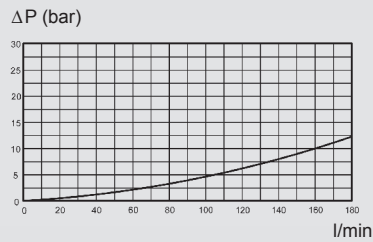

Anticavitation characteristics
TBSD280 and SB280

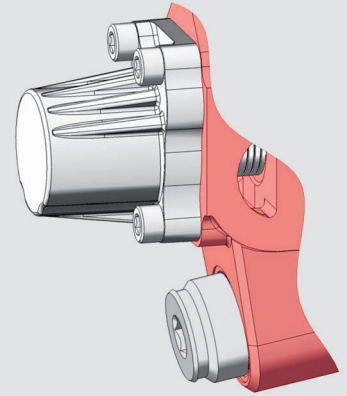

Typical hydraulic circuit diagrams

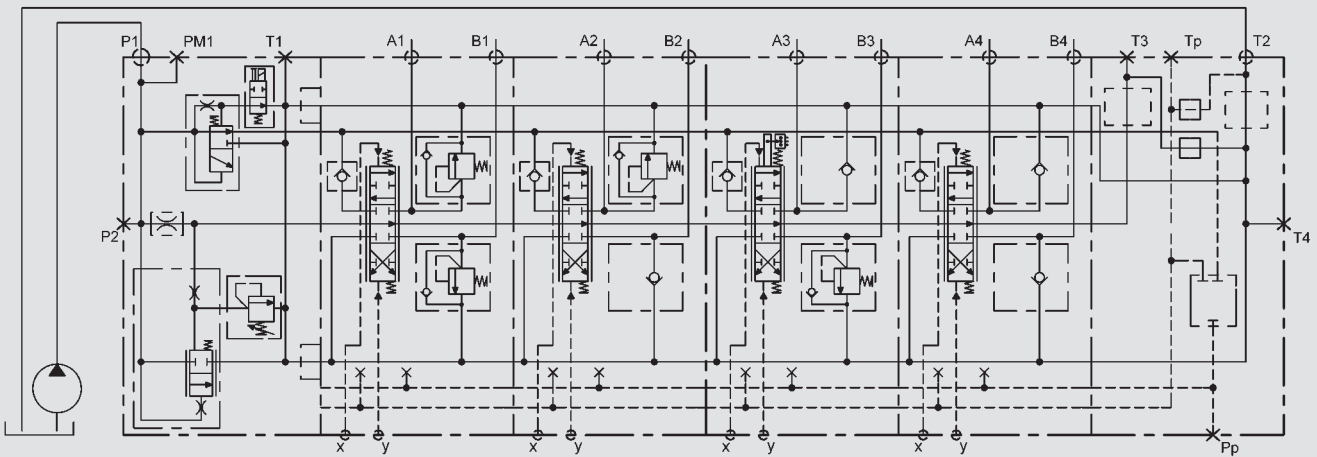

This example shows a DX-6 with parallel circuitry.

The inlet section with flow control function and electrical unloading. A metering orifice determines the center passage flow. A pilot operated relief valve in combination with the flow control performs the main relief valve function. Four working sections all with double acting cylinder spools hydraulically actuated. Section 3 with a spool position indicator. Outlet section machined for pilot pressure supply, back-up pressure and high pressure carry-over (HPCO) but in the example configured with cavity plugs.

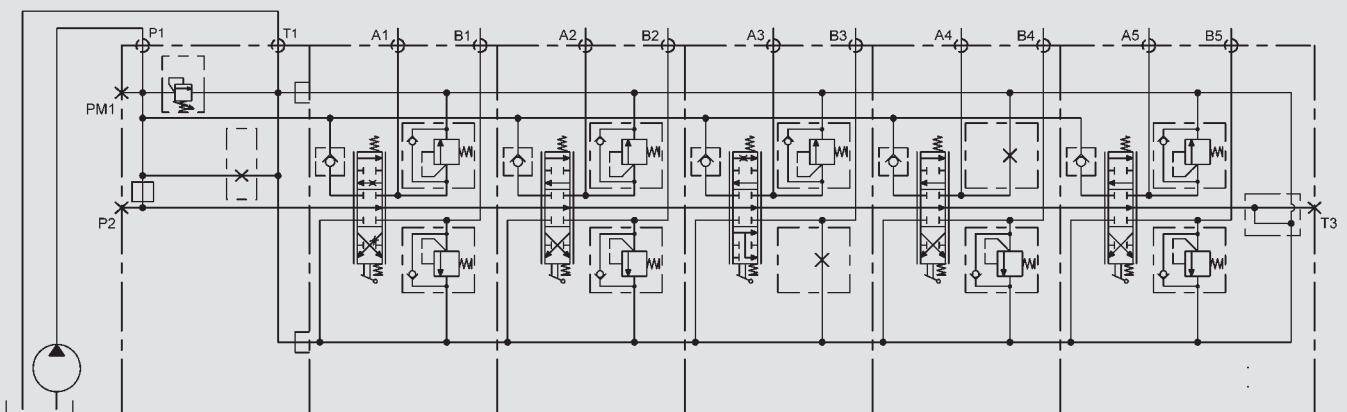

This example shows a DX-6 with parallel circuitry.

The inlet section of standard type with a direct acting main relief valve. Five working sections all manual operated. Section 3 with 3-position regenerative spool. The outlet section with integrated working section with option for HPCO.

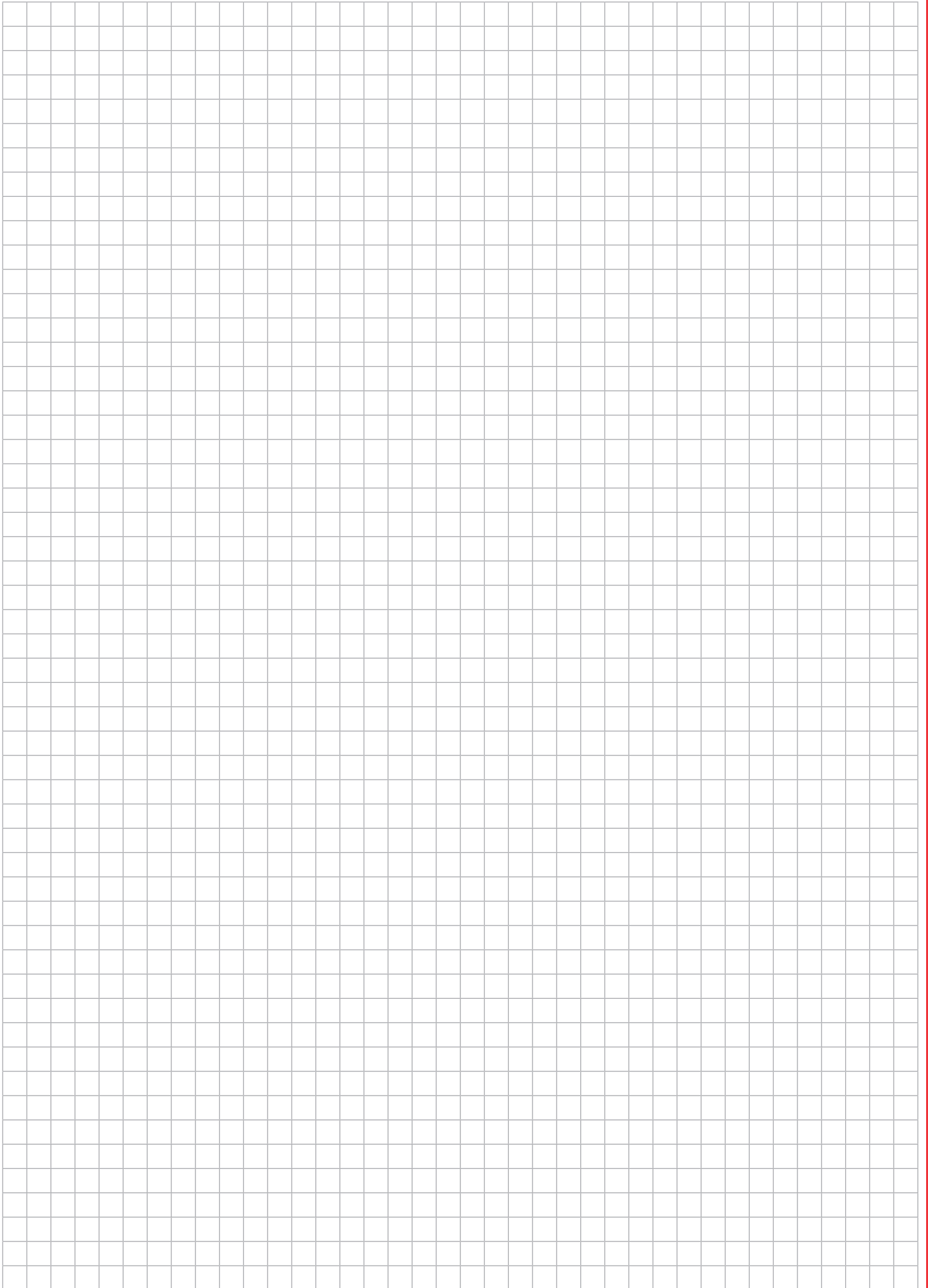

Global Head Office
HYDAC INTERNATIONAL
GMBH

Industriegebiet
D – 66280 Sulzbach/Saar
Germany

Tel.: +49 6897 509-01

Fax: +49 6897 509-577

Internet: www.hydac.com
Email: info@hydac.com

HYDAC North America Locations**USA**www.HYDACusa.com**HYDAC TECHNOLOGY CORPORATION
Filter Division**

2260 City Line Road
Bethlehem, PA 18017

+1.610.266.0100

**HYDAC TECHNOLOGY CORPORATION
Accessory Division**

2204 Avenue C
Bethlehem, PA 18017

+1.610.266.0100

**HYDAC TECHNOLOGY CORPORATION
Electronic Division
Process Filter Division****HYDAC CORPORATION
Accumulator Division**

90 Southland Drive
Bethlehem, PA 18017

+1.610.266.0100

**HYDAC TECHNOLOGY CORPORATION
Cooling System Division**

445 Windy Point Drive
Glendale Heights, IL 60139

+1.630.545.0800

**HYDAC TECHNOLOGY CORPORATION
Hydraulic Division - Compact Hydraulics**

450 Windy Point Drive
Glendale Heights, IL 60139

1749 Paul Avenue
Glendale Heights, IL 60139

+1.630.545.0800

**HYDAC TECHNOLOGY CORPORATION
Mobile Hydraulic Division**

1660 Enterprise Parkway • Suite E
Wooster, OH 44691

+1.610.266.0100

**HYDAC TECHNOLOGY CORPORATION
Cooling System Division**

1051 Airlie Parkway
Denver, NC 28037

+1.610.266.0100 x1805

HYDAC Cylinders LLC

540 Carson Road North
Birmingham, AL 35217

+1.205.520.1220

**HYDAC TECHNOLOGY CORPORATION
HYDAC CORPORATION
Sales Office & Operations**

1718 Fry Road, Suite 100
Houston, TX 77084

+1.281.579.8100

**HYDAC TECHNOLOGY CORPORATION
HYDAC CORPORATION
NE Sales Office**

1660 Enterprise Parkway • Suite E
Wooster, OH 44691

+1.610.266.0100

**HYDAC TECHNOLOGY CORPORATION
HYDAC CORPORATION
SE Sales Office**

1051 Airlie Parkway
Denver, NC 28037

+1.610.266.0100 x1805

**HYDAC TECHNOLOGY CORPORATION
HYDAC CORPORATION
NW Sales Office**

1201 NE 144th Street
Suite 111

Vancouver, WA 98682

+1.610.266.0100

Canadawww.HYDAC.ca**HYDAC CORPORATION**

14 Federal Road
Welland, Ontario, Canada L3B 3P2

+1.905.714.9322

**HYDAC CORPORATION
Sales Office**

Montreal, Québec, Canada J2M 1K9

+1.877.539.3388

**HYDAC CORPORATION
Sales Office**

101 - 18207 114 AVE W
Edmonton, Alberta, Canada T5S 2P6

+1.780.484.4228

Mexicowww.HYDACmex.com**HYDAC INTERNATIONAL SA DE CV**

Calle Alfredo A. Nobel #35
Colonia Industrial Los Reyes
Tlalnepantla, CP. 54075
Edo. de Mexico

+011.52.55.47771262

Note

The information in this brochure relates to the operating conditions and applications described.

For applications or operating conditions not described, please contact the relevant technical department.

Subject to technical modifications.