

Sectional Directional Control Valve RS 210

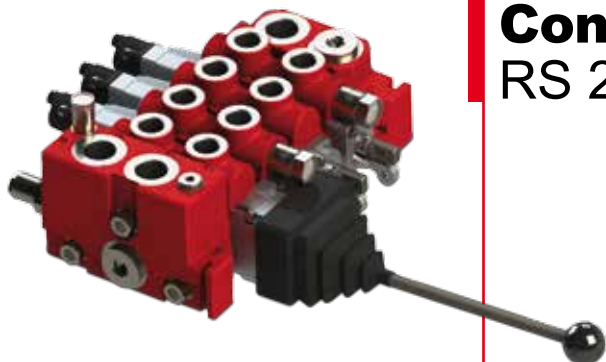

Key valve features

RS 210 is a sectional open center valve, designed for max. operating pressures up to 4,350 psi (300 bar) and max. pump flows up to 20 gpm (75 Lpm).

RS 210 is available with 1 to 10 working sections per valve assembly.

The valve can be used in different systems for parallel as well as tandem circuits. It is designed with an open center for fixed and variable displacement pumps.

The valve can be operated manually, with cable or by pneumatic and electro-pneumatic or electrohydraulic remote control.

RS 210 offers excellent operating characteristics because of the specially designed spools for different applications.

Low and uniform spool forces are the result of careful balancing of the flow forces.

Q-function

The flow control (Q-function) of the inlet section by-passes the major part of the pump flow to tank when the system is idling, still giving access to full pump flow when the services are operated. Besides greatly reducing heat generation this also provides improved controllability characteristics.

Applications

The RS 210 is ideal for applications where you need excellent control characteristics such as cranes, excavators, backhoe loaders, refuse trucks and trailers.

Technical data

Pressures / Flows

Max. operating pressure per port:

P1, P2, P3, P4, A, B ¹ :	4,350 psi	300 bar
T1, T2, T3, T4 ¹ :	300 psi	20 bar

Typical Nominal Inlet Flow:

P1, P2 inlets type A, B, C, E:	20 gpm	75 Lpm
P1, P4 inlets type Q:	20 gpm	75 Lpm

Fluid temperature range: 5°F up to 176°F -15°C up to +80°C

¹ Inlets type A and intermediate sections M uses "A" and "B" designation for P and T connections. Consider the detailed information for the respective part in this data sheet.

Further data

Spool stroke:

Nominal:	±0.25 in	±6 mm
4th position:	+0.45 in	+12 mm

Spool control force spool control 9:

Neutral position:	24.7 lbs	110 N
Max. spool stroke:	31.5 lbs	140 N
Detent in:	>67.4 lbs	>300 N
Detent out:	<22.5 lbs	<100 N

Permissible contamination level: Equal or better than 20/18/14 as per ISO 4406

Viscosity range: .4-15.7 in²/s (cSt) 10 – 400 mm²/s (cst)
Higher viscosity allowed at start up

Leakage A, B → T at 1,500 psi, 32 cSt and 104°F ≤ 13 cc/min (100 bar, 32 cSt and 40°C)

Pressure fluid: Mineral oil and synthetic oil based on mineral oil HL, HLP according to din 51524

Higher values are possible, depending on application. For applications with demands that exceed stated data above, please contact us for consideration.

MTTFd value after consultation with HYDAC.

Further properties and possibilities

- Several different in- and outlet alternatives offering possibility for electrical unloading, connecting and dimensional flexibility
- Very wide program of different spools optimized for various pump flows, applications, system alternatives, etc
- Spool controls for external kick-out and spool position sensing
- Load checks in each working section

- High pressure carry-over
- Left hand and right hand side inlet

General overview

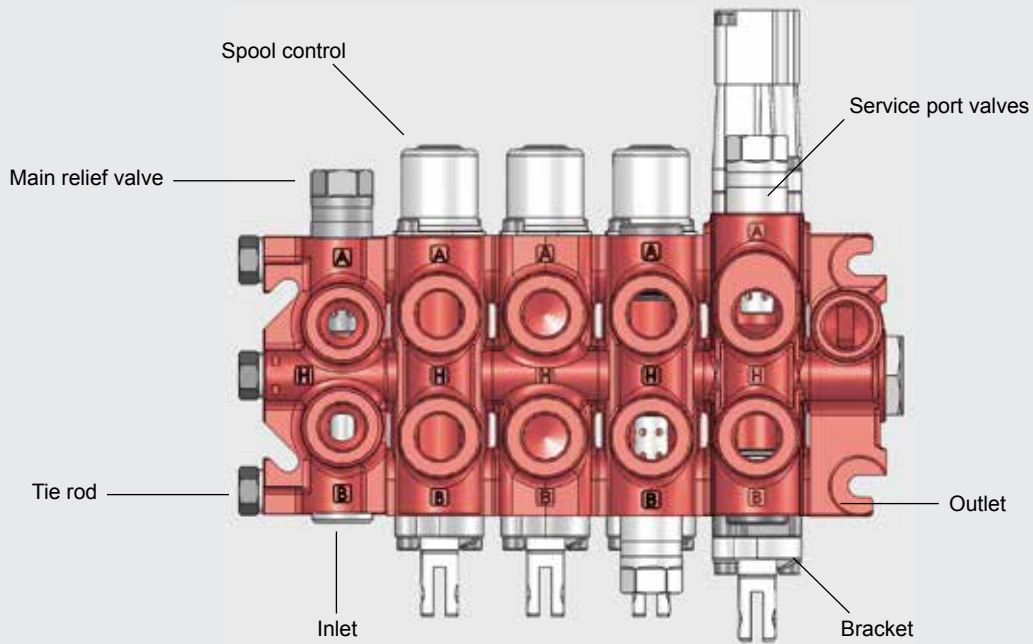

Weight

Inlet section	Weight	
I04A	4.0 lbs	1.8 kg
I04B	3.7 lbs	1.7 kg
I04C	5.5 lbs	2.5 kg
I03E	5.1 lbs	2.3 kg
I02Q	9.9 lbs	4.5 kg
I06Q	9.9 lbs	4.5 kg

Working section	Weight	
S04A	5.3 lbs	2.4 kg
S05B	5.3 lbs	2.4 kg
S04H	6.2 lbs	2.8 kg
S07C	4.2 lbs	1.9 kg
S13A	5.3 lbs	2.4 kg

Outlet section	Weight	
U03A	2.2 lbs	1.0 kg
U03B	3.1 lbs	1.4 kg
U01C	1.5 lbs	0.7 kg

Intermediate section	Weight	
M03A	3.7 lbs	1.7 kg
M03B	3.7 lbs	1.7 kg

Dimensions, spool controls

Type	LA (in)	LA (mm)	LB (in)	LB (mm)
910	1.5	37		
10	2.9	74		
11	3.3	83		
13	2.9	74		
14	2.9	74		
L61	3.8	97		
L62	3.8	97		
L63	3.8	97		
L64	4.0	101		
P	4.1	103		
EP	4.1	103		
HPD	2.8	70	2.8	70
LEF	3.7, 4.1	94, 105		
M19			1.6	41
M29			2.0	50
M111			1.6	41
M211			2.0	50
M2			0.4	9

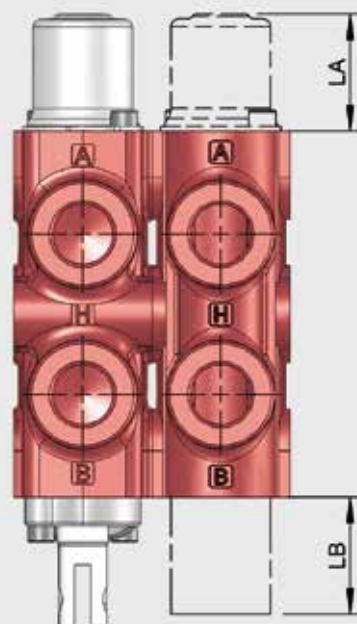

Dimensions inlet and outlet type A – side connection

Port Sizes for US Models

P1	SAE10	T1	SAE12
		T2	SAE10
A	SAE10	B	SAE10
Port A	SAE08	Port B	SAE08

The drawing shows a 4 sectional valve with an inlet and an outlet. The working sections are configured with various types of spool controls. The codes shown on the drawings are referring to the G-threaded port names and -sizes for valve specification.

SAE port sizes are shown in the table. Move the spool "in" to send flow to the B Port.

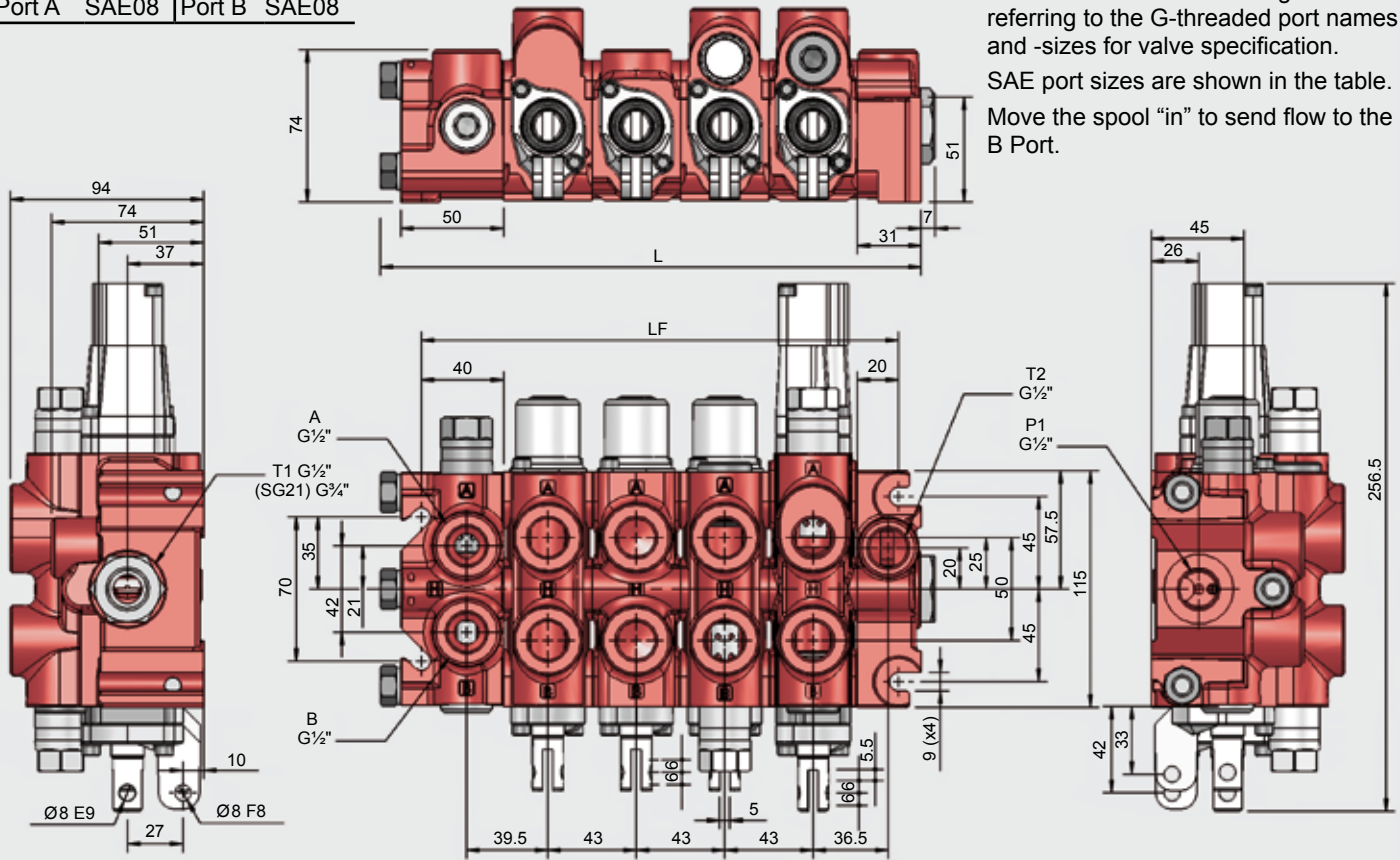

I04A has two pump ports and one tank port.

With the main relief valve fitted in the A-side cavity, the A-port is the pump port and the B-port is the tank port. If the main relief valve is fitted in the B-side cavity the opposite is valid for the pump and tank ports.

For information regarding the outlet – see outlet sections.

1	Inlet type A	I04A
2	Main relief valve	TBD131
3	Plug	PL131

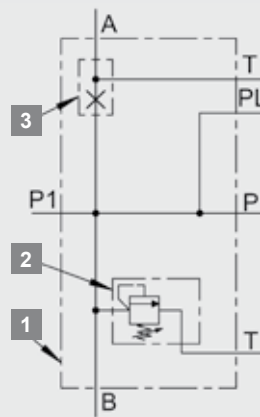

No. of sections	L (in)	L (mm)	LF (in)	LF (mm)
1	5.4	136	4.1	103
2	7.0	179	5.7	146
3	8.7	222	7.4	189
4	10.4	265	9.1	232
5	12.1	308	10.8	275
6	13.8	351	12.5	318
7	15.5	394	14.2	361
8	17.2	437	15.9	404

Pressure drop

Oil temperature / viscosity for all graphs: 104°F (+40°C) / 32 cSt

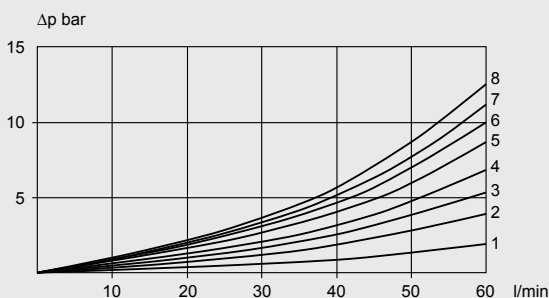

Pressure drop 1-8 sections, P1 – T1, inlet I04A, outlet U03A

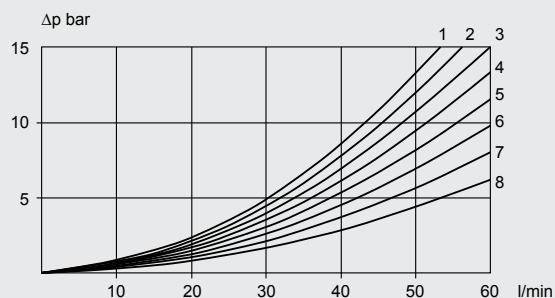

Pressure drop, A/B – T, inlet I04A, outlet 1-8 sections U03A

Dimensions inlet and outlet type B – top connection

Port Sizes for US Models

P1	SAE10	T1	SAE10
T3	SAE10	T4	SAE10
PM	SAE04		

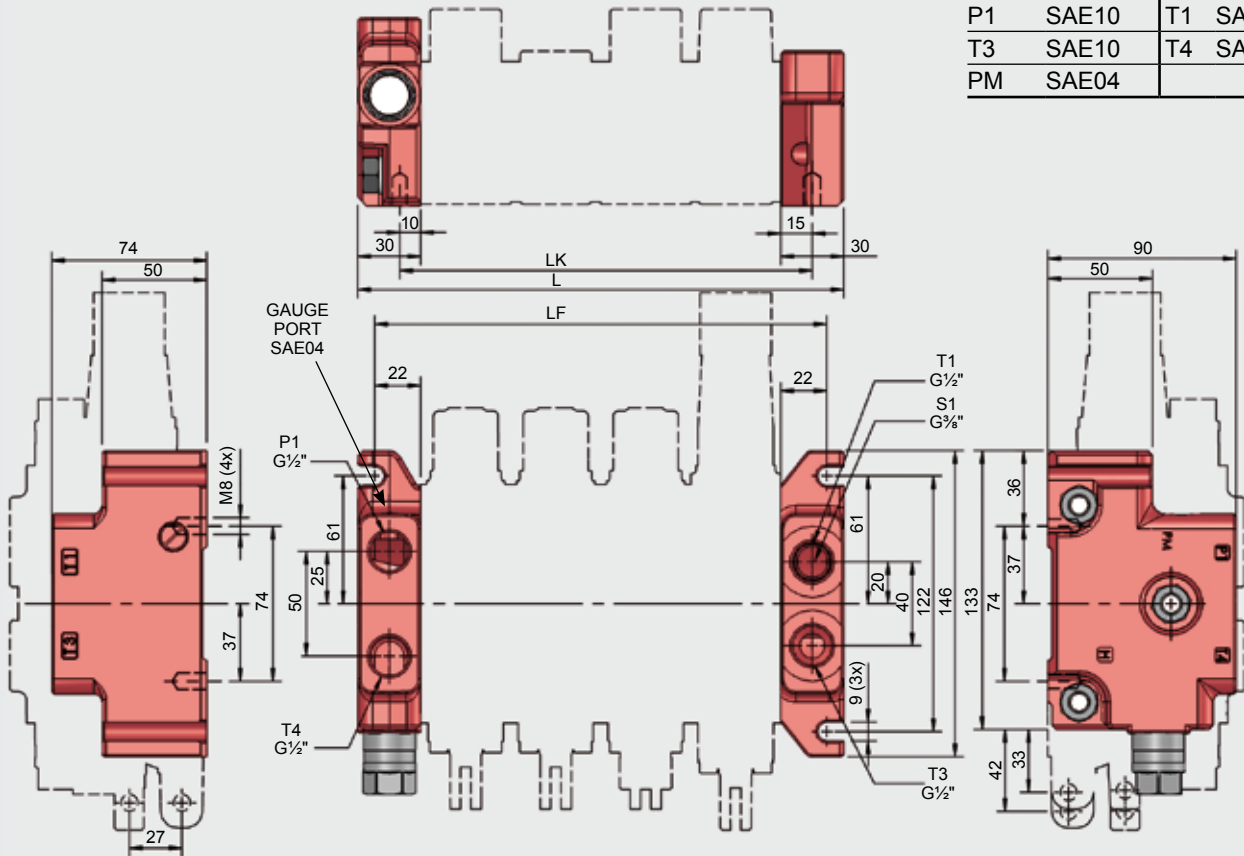

I04B has one pump port and one tank port, both facing upwards. The main relief cavity is on the B-side.

Note: Inlet of type B offers a connection between the tank galleries of A and B sides.

For information regarding the outlet – see outlet sections.

1	Inlet type B	I04B
2	Main relief valve	TBD131

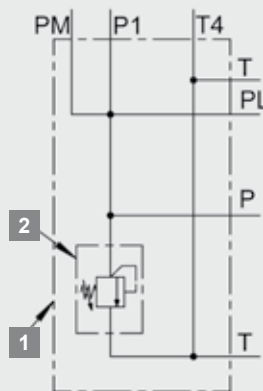

No. of sections	L (in)	L (mm)	LF (in)	LF (mm)	LK (in)	LK (mm)
1	4.1	103	3.4	87	2.7	68
2	5.7	146	5.1	130	4.4	111
3	7.4	189	6.8	173	6.1	154
4	9.1	232	8.5	216	7.8	197
5	10.8	275	10.2	259	9.4	240
6	12.5	318	11.9	302	11.1	283
7	14.2	361	13.6	345	12.8	326
8	15.9	404	15.3	388	14.5	369

Pressure drop

Oil temperature / viscosity for all graphs: 104°F (+40°C) / 32 cSt

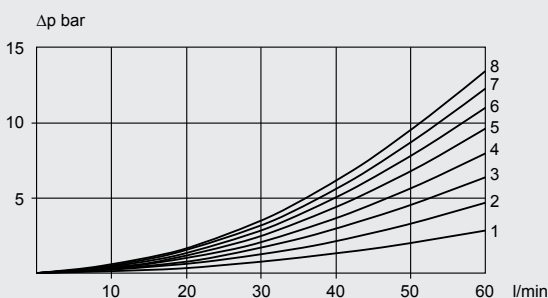

Pressure drop 1-8 sections, P1 – T1, inlet I04B, outlet U05B

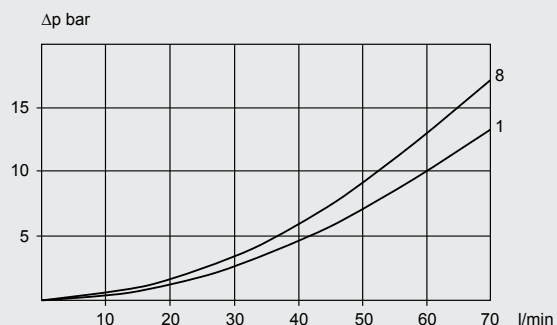

Pressure drop 1 or 8 sections, A/B – T, inlet I04B, outlet U05B

Dimensions inlet and outlet type C – end plate

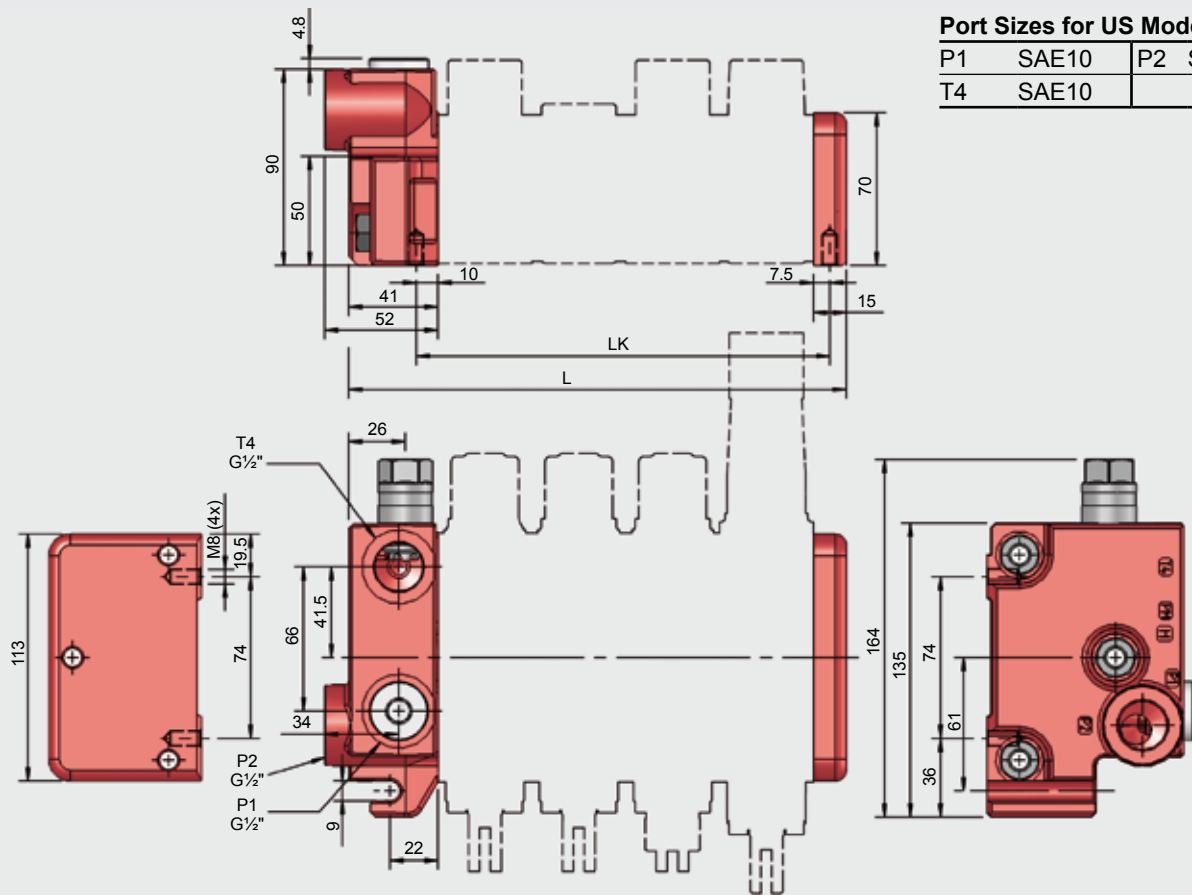

Port Sizes for US Models

P1	SAE10	P2	SAE10
T4	SAE10		

I04C has two pump ports and one tank port.
The main relief valve cavity is on the A-side.

Note: Inlet type C offers a connection between tank galleries of A and B sides.

For information regarding the outlet – see outlet sections.

1	Inlet type C	I04C
2	Main relief valve	TBD131

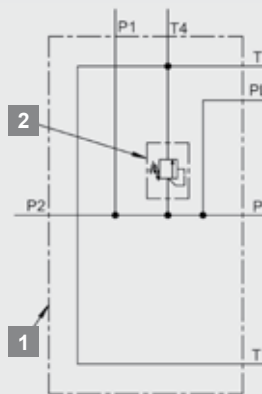

No. of sections	L (in)	L (mm)	LK (in)	LK (mm)
1	3.9	98	2.4	61
2	5.6	141	4.1	104
3	7.2	184	5.8	147
4	8.9	227	7.5	190
5	10.6	270	9.2	233
6	12.3	313	10.9	276
7	14.0	356	12.6	319
8	15.7	399	14.3	362

Pressure drop

Oil temperature / viscosity for all graphs: 104°F (+40°C) / 32 cSt

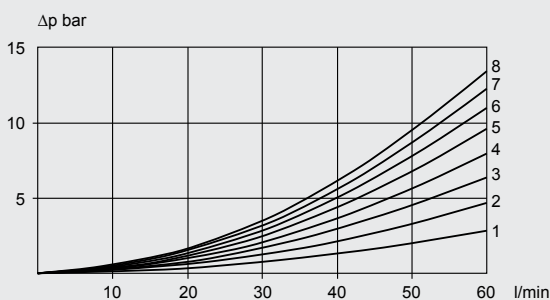

Pressure drop 1-8 sections, P1 – T4, inlet I04C, outlet U01C

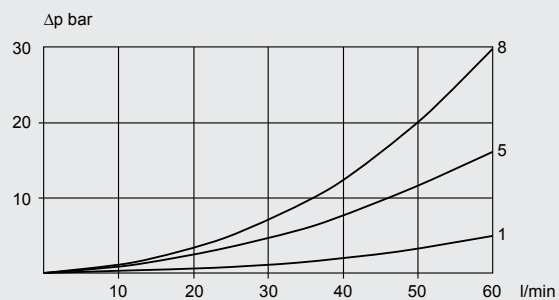

Pressure drop 1, 5 and 8 sections A, B – T, inlet I04C, outlet U01C

Dimensions inlet type E – with electrical unloading

Port Sizes for US Models

P1	SAE08	T4	SAE08
----	-------	----	-------

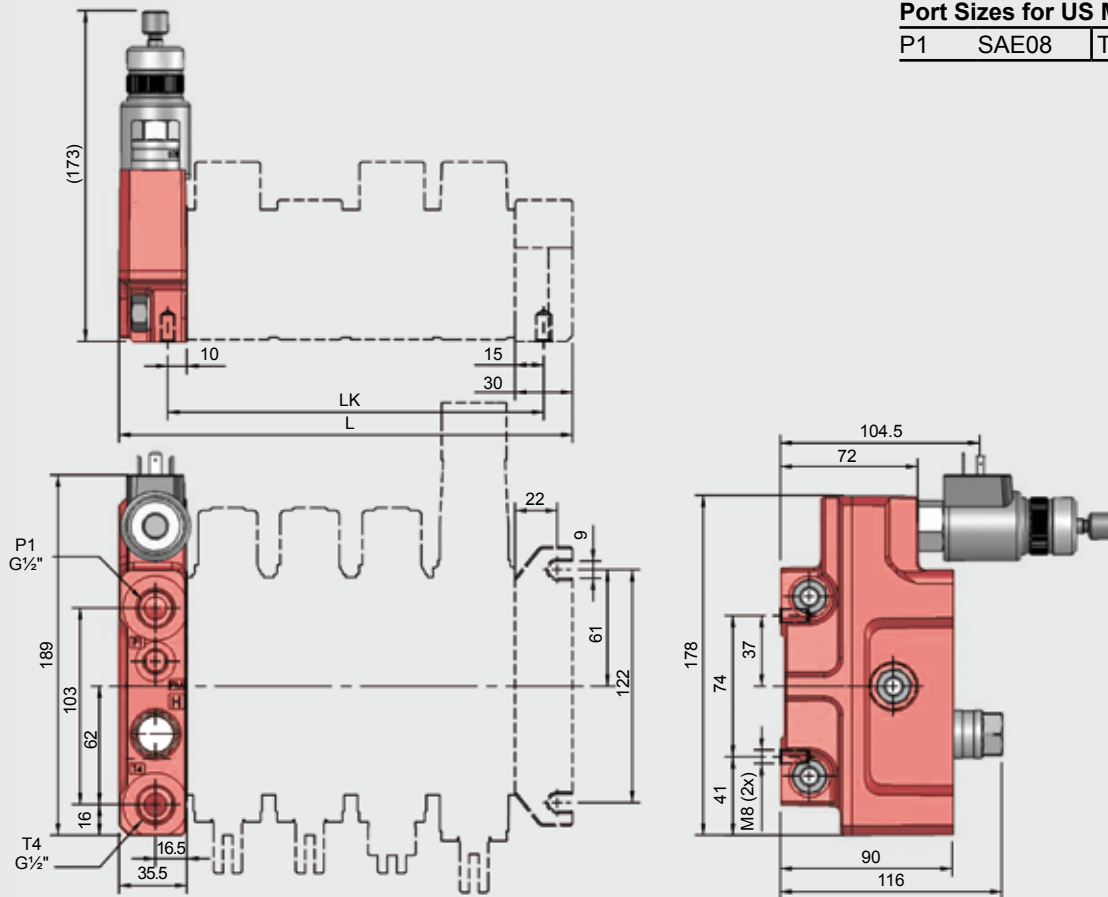

I03E has one pump port and one tank port, both facing upwards. The main relief cavity is facing upwards.

Main relief options: TBD160 or TBS400 up to max. 4,350 psi (300 bar).

The cavity for the electrical unloading valve is facing upwards. The A- and B-side tank channels are connected.

1	Inlet type E	I03E
2	Electrical unloading valve	EU912
2	Electrical unloading valve	EU926
3	Main relief valve	TBD160
3	Main relief valve	TBS400

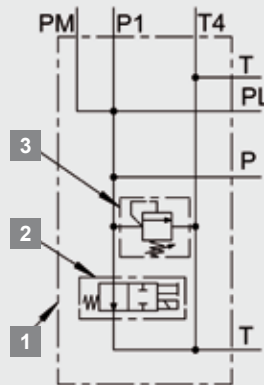

No. of sections	L (in)	L (mm)	LK (in)	LK (mm)
1	4.2	107	2.7	68
2	5.9	150	4.4	111
3	7.6	193	6.1	154
4	9.3	236	7.8	197
5	11.0	279	9.4	240
6	12.7	322	11.1	283
7	14.4	365	12.8	326
8	16.1	408	14.5	369

Pressure drop

Oil temperature / viscosity for all graphs: 104°F (+40°C) / 32 cSt

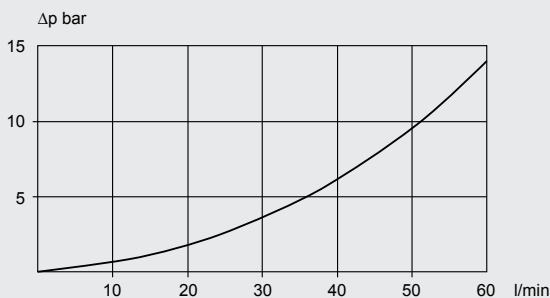

Pressure drop, P1 – T4, inlet I03E, unloaded

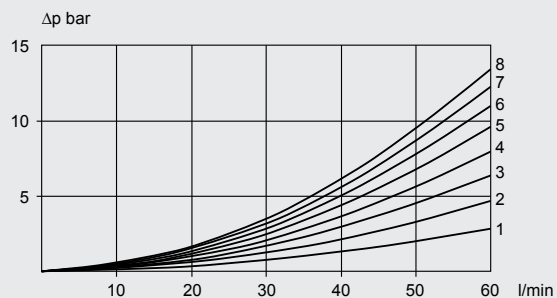

Pressure drop 1-8 sections, P1 – T1/T3, inlet I03E, outlet U05B

Dimensions inlet type I02QU – with by-pass and electrical unloading

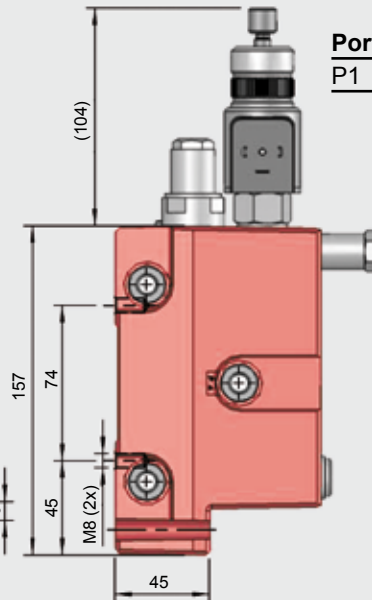
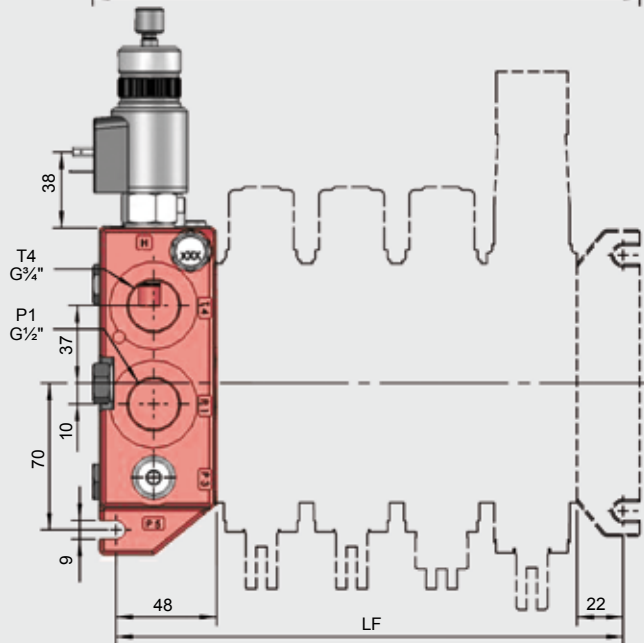
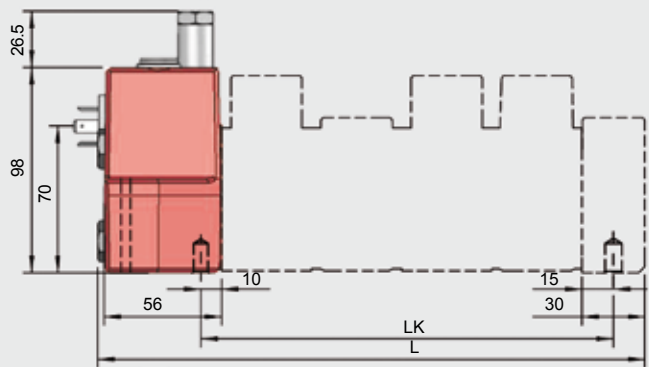

Port Sizes for US Models

P1	SAE12	T4	SAE12
----	-------	----	-------

No. of sections	L (in)	L (mm)	LF (in)	LF (mm)	LK (in)	LK (mm)
1	5.3	135	4.4	113	2.7	68
2	7.0	178	6.1	156	4.4	111
3	8.7	221	7.8	199	6.1	154
4	10.4	264	9.5	242	7.8	197
5	12.1	307	11.2	285	9.4	240
6	13.8	350	12.9	328	11.1	283
7	15.5	393	14.6	371	12.8	326
8	17.2	436	16.3	414	14.5	369

I02QU is an inlet section with flow control, main relief valve and unloading function.

When the system is idling a small regulated flow passes the center gallery of the valve. Excess pump flow is routed directly to tank.

The regulated flow is defined by the flow control valve FKA283 and the metering orifice PF.

When a spool is operated the whole pump flow is instantly available for the user. The low center gallery flow during idling conditions reduce pressure drop P – T through the valve body, and this facilitates higher pump flow without negative influence on the spool forces and heat generation.

I02QU also is equipped with main relief valve TB12, which together with flow control FKA283, function as a pilot operated main relief valve. The Q-inlet can be equipped with a solenoid operated valve for electrical unloading.

The available metering orifices are PF11 and PF12.

In combination with FKA283 they provide:

PF11: 25 l/min; PF12: 28 l/min

A lower flow creates less pressure drop P – T.

A spool that matches the flow improves the operating characteristics.

1	Inlet type Q	I02QU
2	Electrical unloading valve	EU912
2	Electrical unloading valve	EU926
3	Main relief valve	TB12
4	Flow control	FKA283/2
5	Metering orifice, diam 5.7 mm	PF12

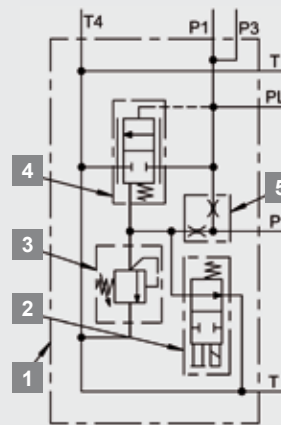

Pressure drop

Oil temperature / viscosity for all graphs: 104°F (+40°C) / 32 cStt

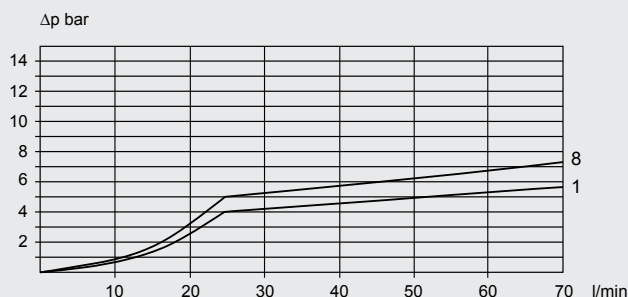

Pressure drop 1 and 8 sections, P1 – T4, inlet I02QU/I06QU, with flow control FKA283/2 and PF12, outlet U05B

Dimensions inlet type I06QU – with by-pass and electrical unloading

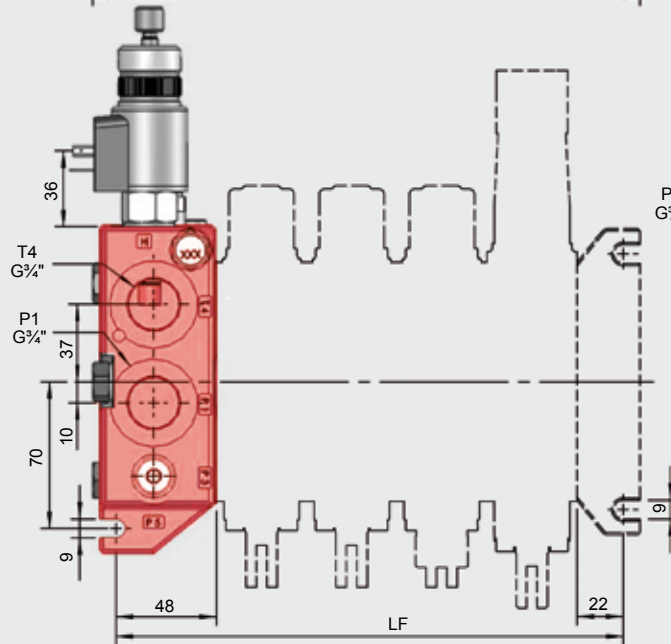
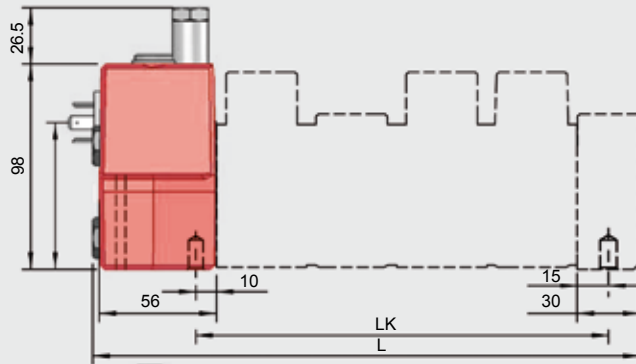

Port Sizes for US Models

P1	SAE12	P4	SAE12
T4	SAE12		

I06QU has the same functions as I02QU but with an added special check valve FSB3 in the signal gallery to damp the unloading function of the flow control valve FKA.

I06QU also provides an additional pump port.

1	Inlet type Q	I06QU
2	Electrical unloading valve	EU912
2	Electrical unloading valve	EU926
3	Main relief valve	TB12
4	Damp check valve	FSB3
5	Flow control	FKA283/2
5	Flow control	FKA283/3
6	Metering orifice, diam 5.4 mm	PF11
6	Metering orifice, diam 5.7 mm	PF12

No. of sections	L (in)	L (mm)	LF (in)	LF (mm)	LK (in)	LK (mm)
1	5.3	135	4.4	113	2.7	68
2	7.0	178	6.1	156	4.4	111
3	8.7	221	7.8	199	6.1	154
4	10.4	264	9.5	242	7.8	197
5	12.1	307	11.2	285	9.4	240
6	13.8	350	12.9	328	11.1	283
7	15.5	393	14.6	371	12.8	326
8	17.2	436	16.3	414	14.5	369

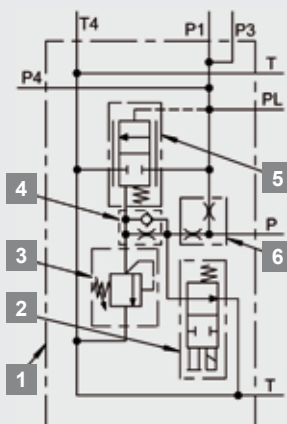

Pressure drop

Oil temperature / viscosity for all graphs: 104°F (+40°C) / 32 cSt

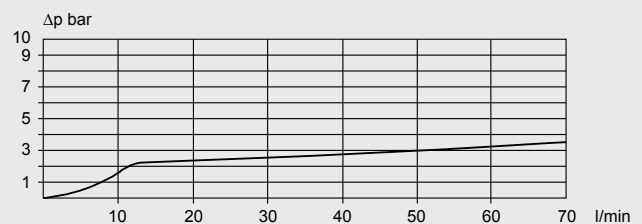

Pressure drop, P1 – T4, inlet I02QU/I06QU, unloaded

Working sections

S04A

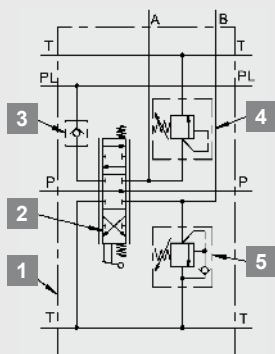

S04A, for 3-position spool and cavities for service port valves

1	Spool section	S04A
2	Spool	
3	Check valve	MB01
4	Port relief valve	TBD121
5	Port relief and anticavitation valve	TBSD121

S05B

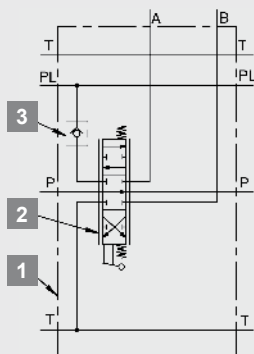

S05B, for 3-position spool without cavities for service port valves

1	Spool section	S05B
2	Spool	
3	Check valve	MB01

S04H

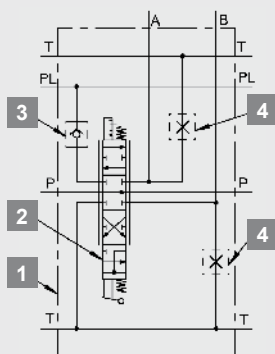

S04H, for 4-position spool and cavities for service port valves

1	Spool section	S04H
2	Spool	
3	Check valve	MB03
4	Plug	P121

S07C

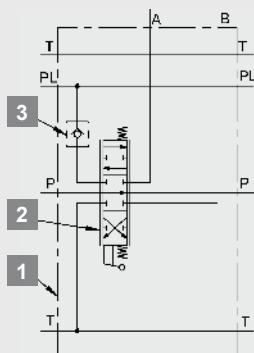

S07C, for 3-position spool without service port valve possibility

1	Spool section	S07C
2	Spool	
3	Check valve	MB01

S13A

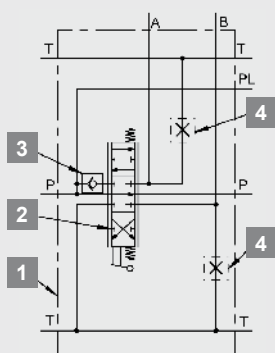

S13A, for 3-position spool and cavities for service port valves for tandem

1	Spool section	S13A
2	Spool	
3	Check valve	MB01
4	Plug	P121

Intermediate sections

M03A

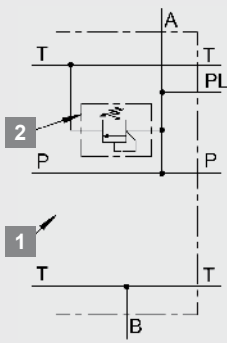

M03A

M03A is an intermediate inlet section used in dual circuit systems.

The A-port is for pump connection and the B-port is for tank connections. The main relief valve cavity is on the A-side. The second circuit pump is connected to port A. If the first circuit pump flow is connected to the inlet section and spool sections upstream of M03A is not used, both pump flows are available for use downstream of M03A. The sum of the pump flow should not exceed max. permissible flow of 50 l/min. The tank gallery is common for all sections.

1	Intermediate section	M03A
2	Main relief valve	TBD131

M03B

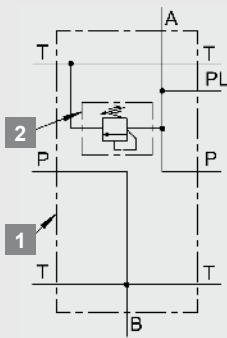

M03B

M03B is an intermediate inlet section used for two completely separated circuits.

The A-port is for pump connection and the B-port is for tank connections. The main relief valve cavity is on the A-side. The sum of the pump flow should not exceed max permissible flow of 50 l/min. The tank gallery is common for all sections.

1	Intermediate section	M03B
2	Main relief valve	TBD131

Outlet sections

U03A

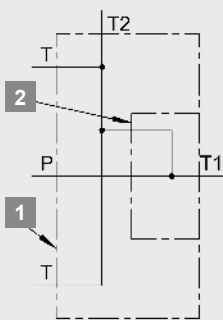

U03A

U03A has two tank ports, T2 on the top and T1 on the side. For series connection a high pressure carry-over nipple should be fitted in T1. In this case an alternative tank port always has to be connected to the tank.

1	Outlet section	U03A
2	High pressure carry over nipple	SU23

U03A

High pressure carry-over nipple SU23 is fitted in port T1.

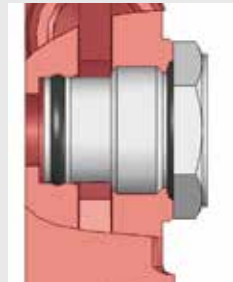

U05B

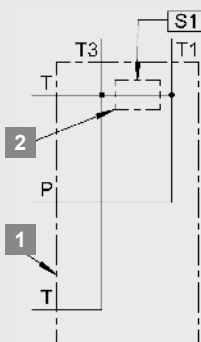

U05B

U05B has two tank ports, both facing upwards. For series connection a high pressure carry-over plug PS20 should be fitted in location S1 in port T1. In this case an alternative tank port always has to be connected to the tank.

1	Outlet section	U05B
2	Plug (S1)	PS20

U05B

High pressure carry-over plug PS20 is fitted through port T1 in location S1. T1 is now port for series connection.



U01C

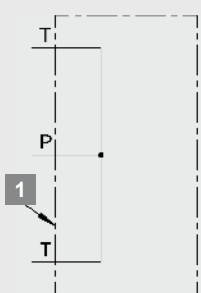

U01C

U01C is an end plate without porting.

1	Outlet section	U01C
---	----------------	------

Electrical unloading valve

The electrical unloading valve is a 2-way, normally open, solenoid type cartridge valve. It is an option in inlet sections I02QU, I06QU and I03E.

It is intended for emergency stop and for pressure drop / heat generation reduction.

In Q-inlets a de-energized unloading valve drains the pilot circuit so that the FKA283 spool dumps the whole pump flow directly to tank.

In inlet I01E a de-energized unloading valve dumps the whole pump flow to tank.

Data

Rated flow:	10.5 gpm (40 Lpm)
Power consumption:	27 W
Rated voltage:	12 or 24 V
Max voltage variation:	+/- 15 %
Duty factor ¹ :	100 %
Connection:	Hirschmann ISO 4400 DIN 43650 ²
Protection class:	IP65

¹ Sufficient cooling must be secured

² Other Connections available upon request.

The unloading valve has manual override.

E912 and E926 has push and twist type pin operation.

This pin is sealable.

PE20 is the plug for the cavity.

Codes

EU912	push and twist type override 12 V
EU926	push and twist type override 24 V

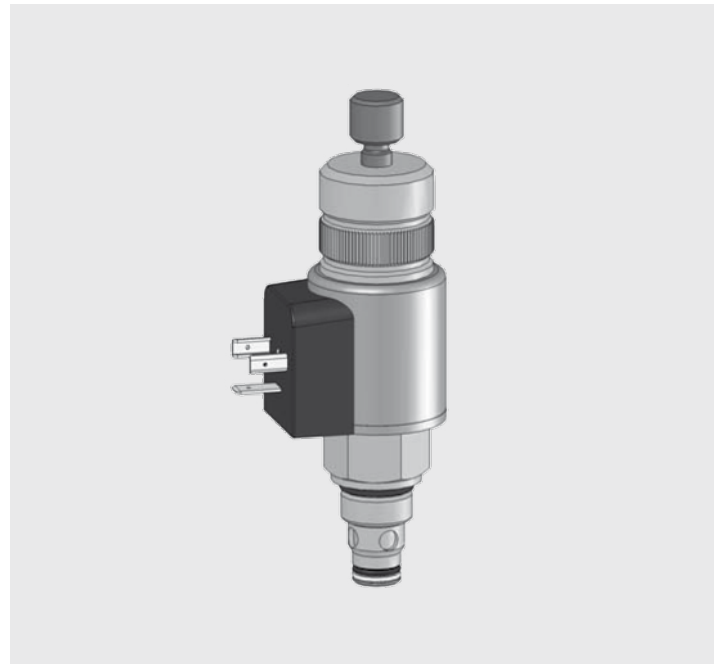

Main relief valves

Main relief valve TBS400

TBS400 is a pilot operated relief valve for the primary circuit. It is adjustable and sealable.

It is optional in inlet section I01E.

- Setting range: 500-4,350 psi (35-300 bar)
- Setting range step: 100 psi (7 bar)

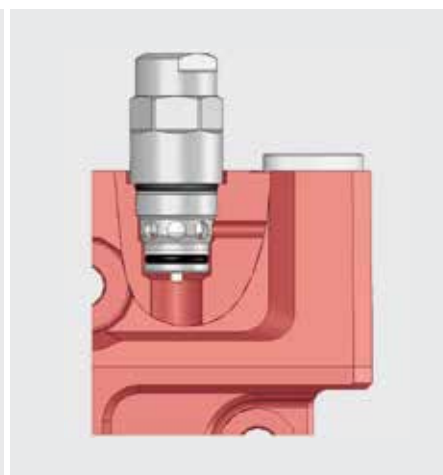
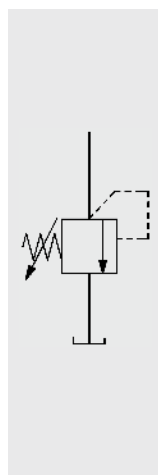
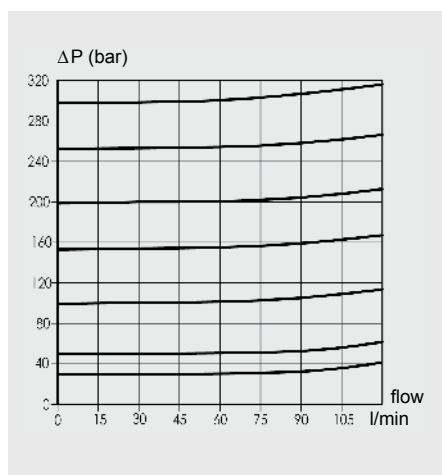

Main relief function with TB12

The flow control valve FKA283, in combination with the relief valve TB12, form the pilot operated main relief function of the Q-inlets.

TB12 is adjustable and sealable.

- Setting range: 500-4,350 psi (35-300 bar)
- Setting range step: 100 psi (7bar)

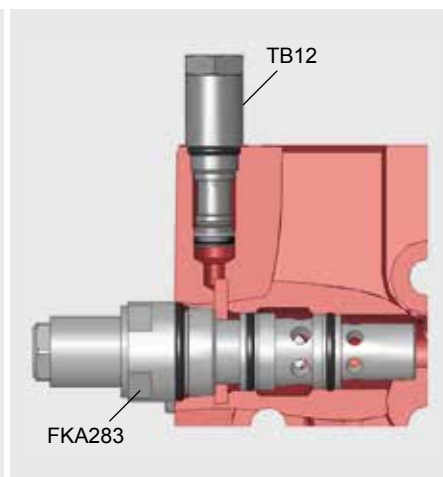
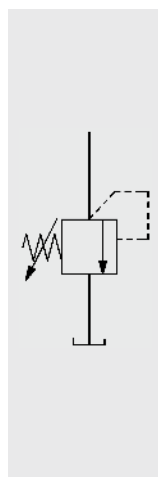
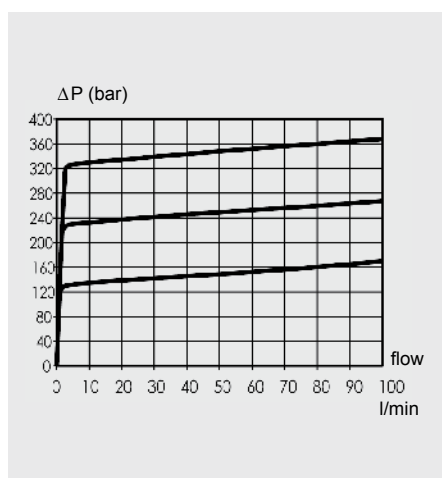

Main relief valve TBD131

TBD131 is a differential area, direct acting relief valve for the primary circuit. It is adjustable and sealable.

TBD131 is used in inlet sections I04A, I04B, I04C and intermediate sections M03A and M03B

- Setting range: 500-4,350 psi (35-300 bar)
- Setting range step: 100 psi (7bar)

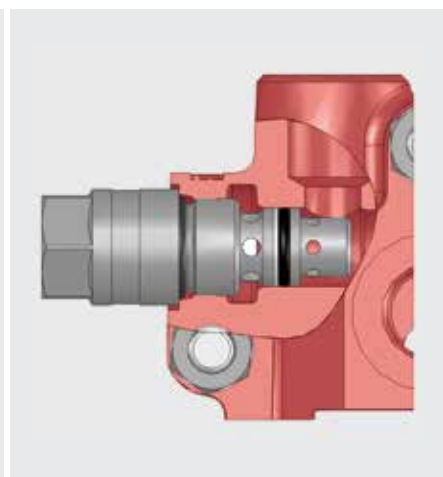
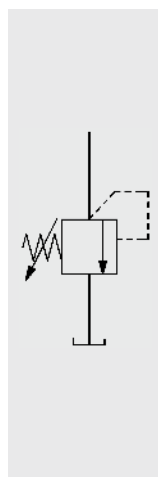
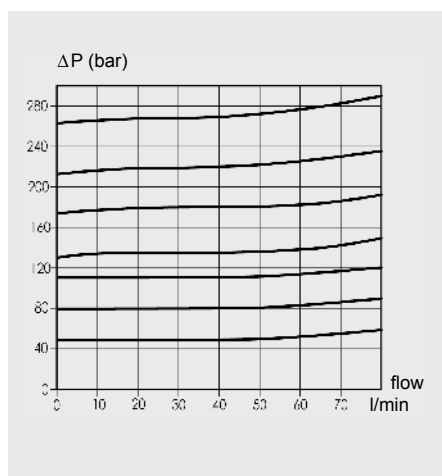

Main relief valve TBD160

TBD160 is a differential area, direct acting relief valve for the primary circuit. It is adjustable and sealable.

TBD160 is optional in inlet I03E.

- Setting range: 500-4,350 psi (35-300 bar)
- Setting range step: 100 psi (7bar)

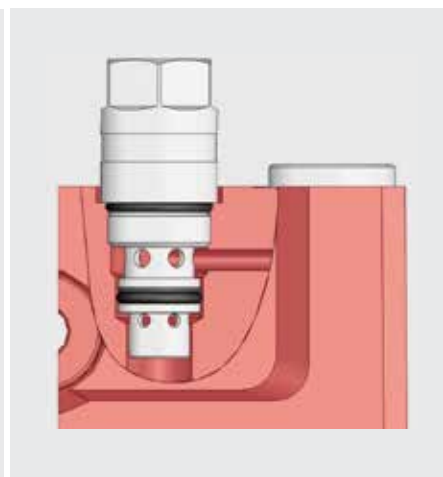
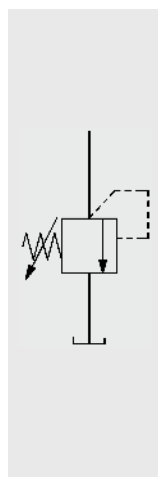
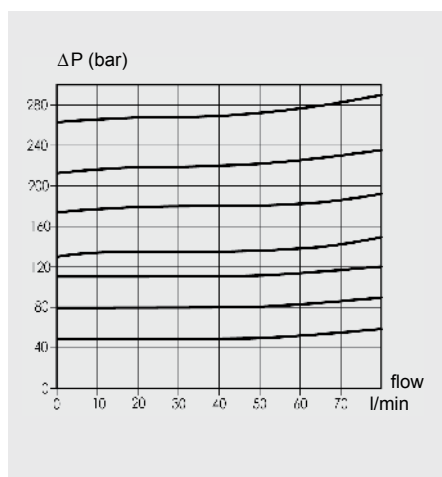

Spools

The RS210 spools are available in variety of flows and styles to accommodate most design requirements. Since the development of spools is a continuous process and all available spools are not described in this data sheet, contact HYDAC for advice on choosing spools in order to optimize your valve configuration.

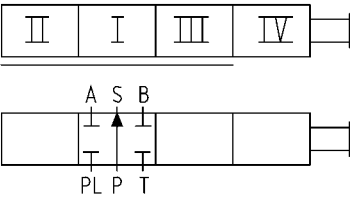
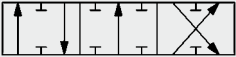
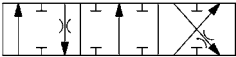
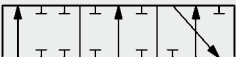
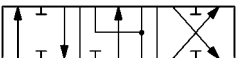
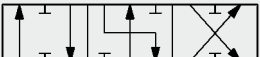
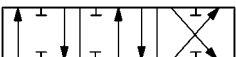
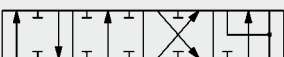
		Spools for general use	
		Function	Standard spools ¹
		Double acting spool	1K
		Slewing spool, gentle operating	1M
		Single acting spool P - A	2K
		Motor spool	4K
		Motor spool A - T	4KA
		Motor spool B - T	4KB
		Double acting spool with 4th pos. for float	3K

¹Note: For other spools, consult factory.

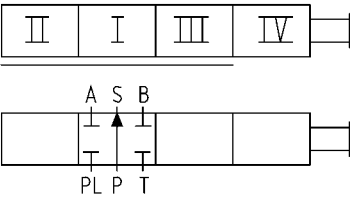
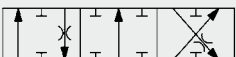
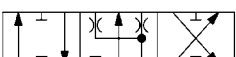
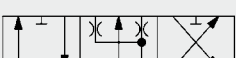
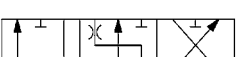
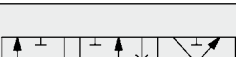
	Spools designed for cranes	Flow range		
		Function	5-8 gpm (20-30 Lpm)	8-12 gpm (30-45 Lpm)
	For slewing function. In combination with spool control 918 only.	12SA	14SA	124SA
	For use with load holding valves. Assymmetric. B-port to be connected to piston side of cylinder.	12ZA	14ZA	124ZA
	For use with load holding valves.	12ZB	14ZB	124ZB
	For use with load holding valves. Assymmetric. A-port to be connected to piston side of cylinder.	12XA	14XA	124XA
	For use with load holding valves. Assymmetric. B-port to be connected to piston side of cylinder.	12YA	14YA	124YA

*Note: Spools for flow range 9-13 gpm (35 - 50 Lpm) only in combination with Q-inlets.
For higher flows, consult factory.

Spool controls – A-side

Spool control 9 9 Spring centered. 9W for cable control	
Spool control 10 Detents at positions 1, 2 and 3	
Spool control 11 Spring centering with detent at position 4	
Spool control 13 Spring centering with detent at position 2	
Spool control 14 Spring centering with detent at position 3	
Spool control P Pneumatic*	
Spool control EP Electro / pneumatic on / off**	
Spool control HPD Hydr. proportional Pilot pressure 87 - 232 psi (6-16 bar) Max. pilot pressure 362 psi (25 bar)*	
Spool control L61 External hydraulic kick-out from inserted spool*	
Spool control L62 External hydraulic kick-out from extended spool***	
Spool control L63 External hydraulic kick-out from inserted and extended spool***	
Spool control L64 External hydraulic kick-out from inserted and extended spool, locking neutral position*	
Spool Control HLS 200 Spool position indicator. Operating range 10 - 30 V	

* Connection G 1/8" BSP

*** Connection G 1/4" BSP

** Power consumption	4.8 W
Rated voltage	24 V
Max voltage variation	+/- 10 %
Duty factor	100 %
Connection	according to EN175301-803/B
Protection class	IP65

Spool controls – B-side

Bracket M19 Bracket for 3-position spool, gear ratio 9:1	Bracket M2 Bracket for 3-position spool, without ear
Bracket M29 Bracket for 4-position spool, gear ratio 9:1	3W Cap for 3-position spool controlled by cable
Bracket M111 Bracket for 3-position spool, gear ratio 11:1	4W Cap for 4-position spool controlled by cable
Bracket M211 Bracket for 4-position spool, gear ratio 11:1	Lever M2K250 Coordinate lever for spool with 3 or 4 pos.
Spool control M02 M02 is a spool actuator that assures dry and sealed spool ends for a manual lever	

Levers

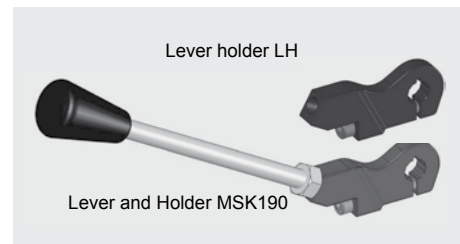

Lever and Holder MSK190

The lever holder (LH) is for use together with spool actuator of type M1/EHM.

The lever holder is delivered in combination with a lever as MSK190

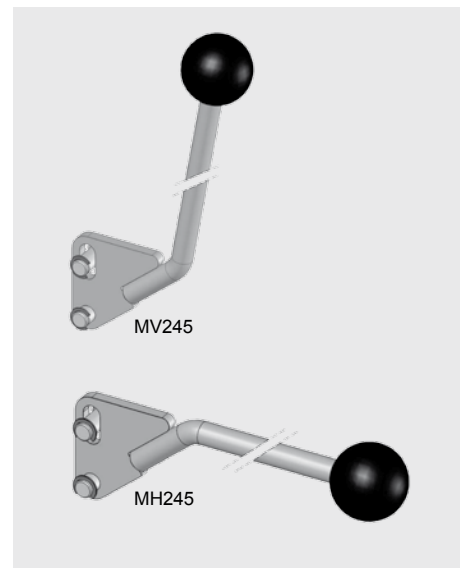

Lever MV/MH

Lever for use in combination with open spool ends and a bracket M19/M29. When mounted on a valve, the lever MH stands in a horizontal position and MV stands in a vertical position. Lever length 145 or 245 mm.

Service port valves

Port relief valve TBD121

TBD121 is a direct acting relief valve for the secondary circuit. It is adjustable and sealable.

- Setting range:
500-4,350 psi (35-300 bar)
- Setting range step:
100 psi (7bar)

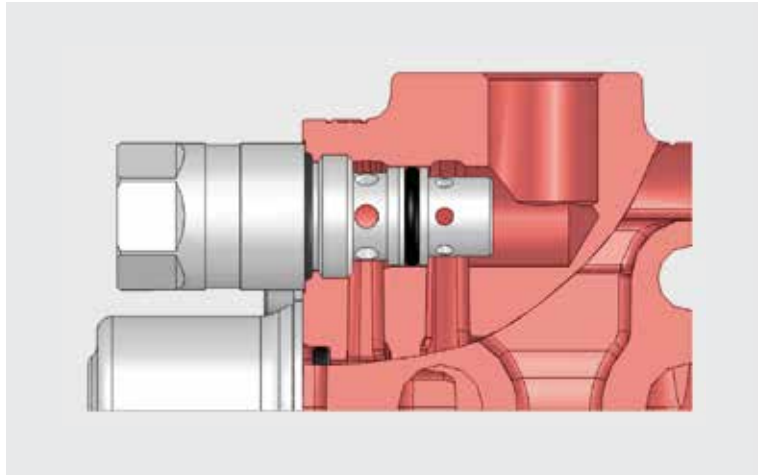
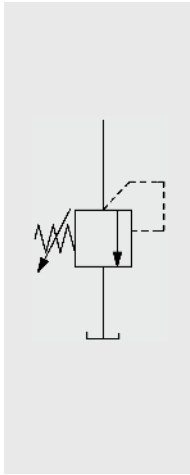

Port relief and anticavitation valve TBSD121

See TBD121 and SB160 for functional principles.

- Setting range:
500-4,350 psi (35-300 bar)
- Setting range step:
100 psi (7bar)

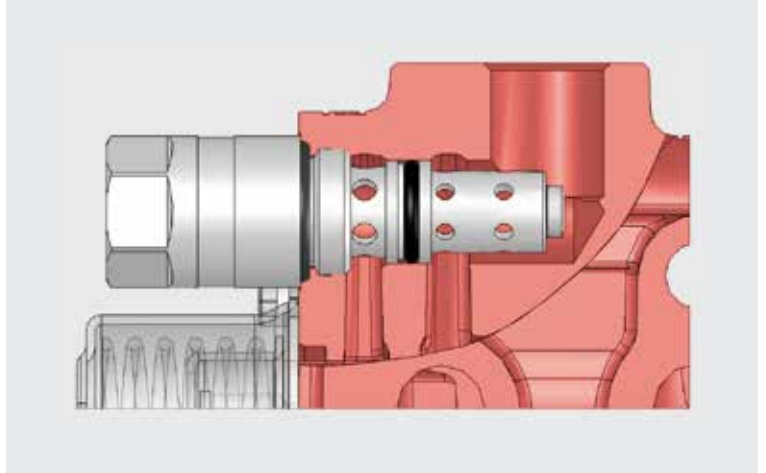
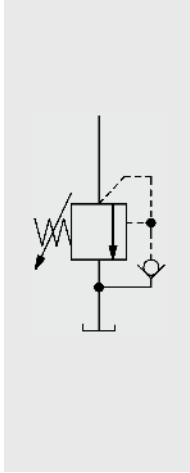

Anticavitation valve SB160

The anticavitation valve ensures that, in the event of a lower pressure in the cylinder port than in the tank, oil can be drawn from the system oil tank to the consumer.

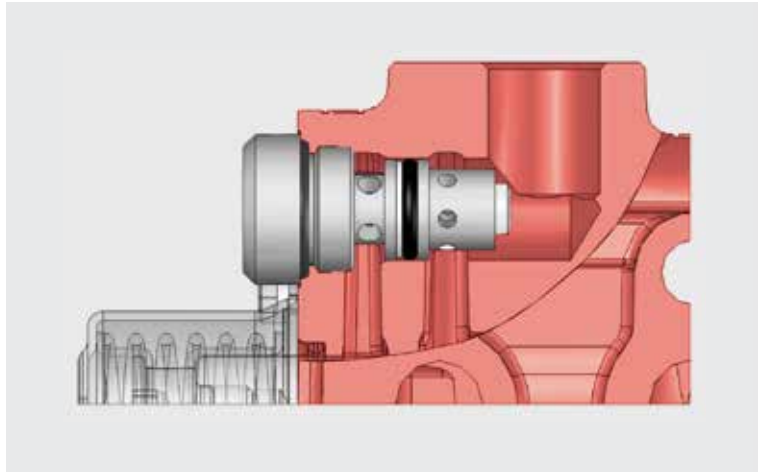
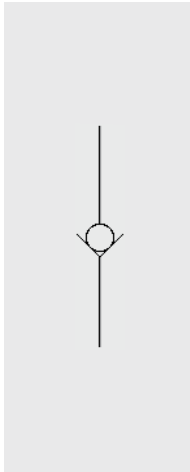

Anticavitation and pressure drop characteristics

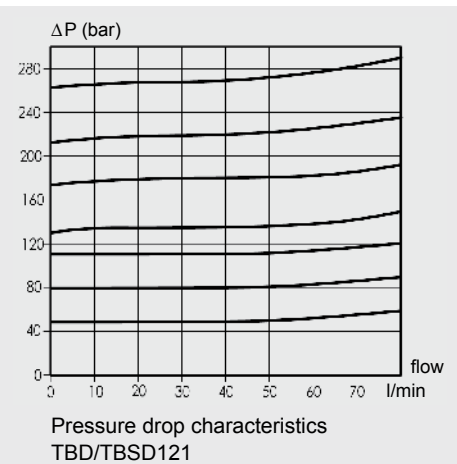
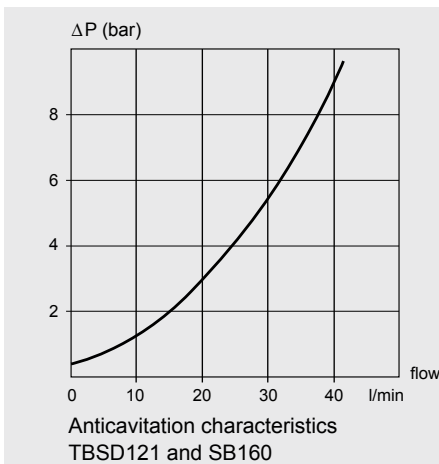

Typical hydraulic circuit diagrams

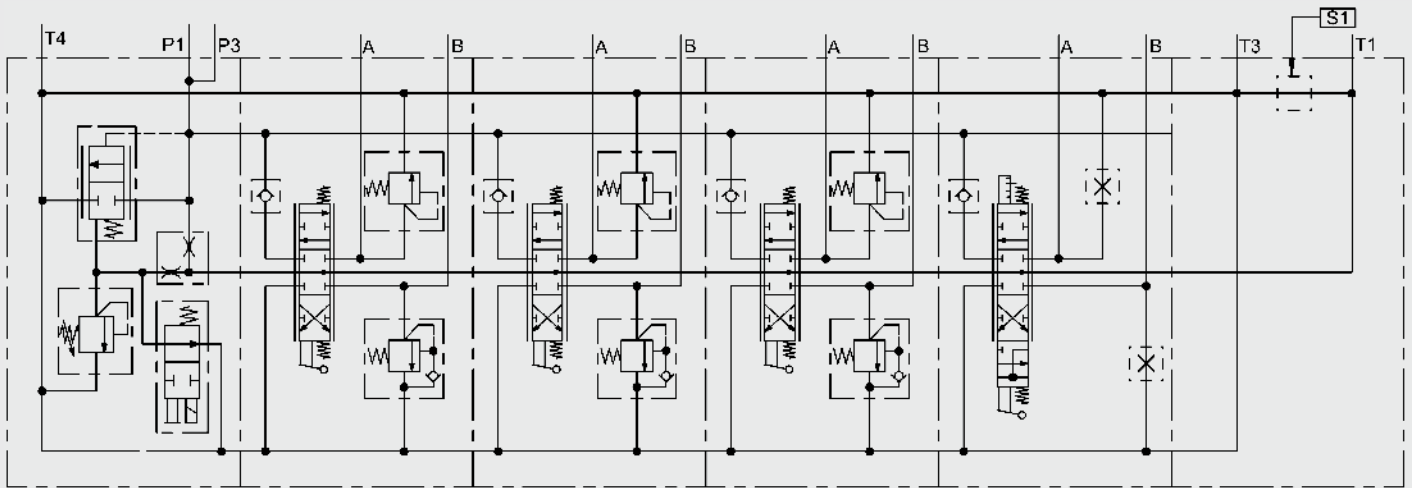

Hydraulic circuit diagram for a four sectional RS 210 valve.

It is fitted with a Q-inlet with electrical unloading.

The first three sections contain 3-positions spools for double acting functions and port relief and anticavitation valves.

The fourth section contains a 4-position spool for double acting functions with float position in position 4. The outlet gives possibility for high pressure carry-over (if S1 is plugged).

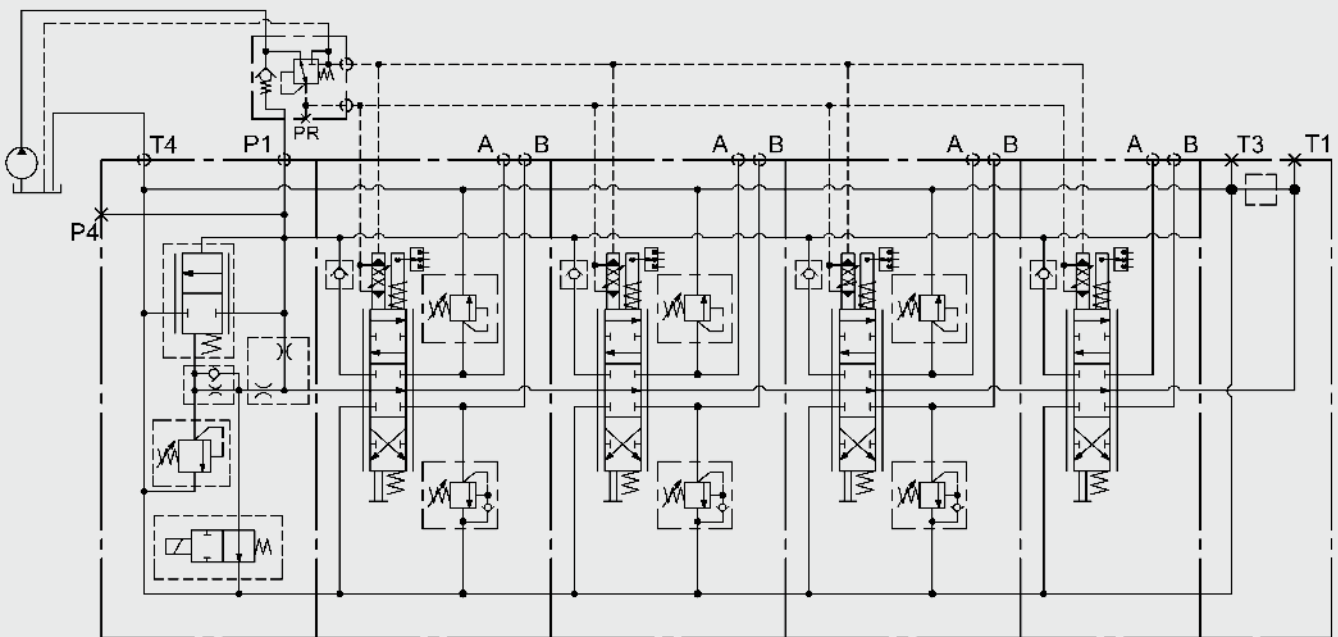

The circuit diagram shows a complete RS 210 valve, 4 sections with an inlet with flow regulator ("Q-inlet") and completed with pilot supply and spool controls for remote control.

Note the separate piping to tank for the return flow from the remote control. It is required to pipe up the system in that way in order to avoid high pressure and pressure peaks in the return line.

Ordering Details RS210 Sectional Control Valve

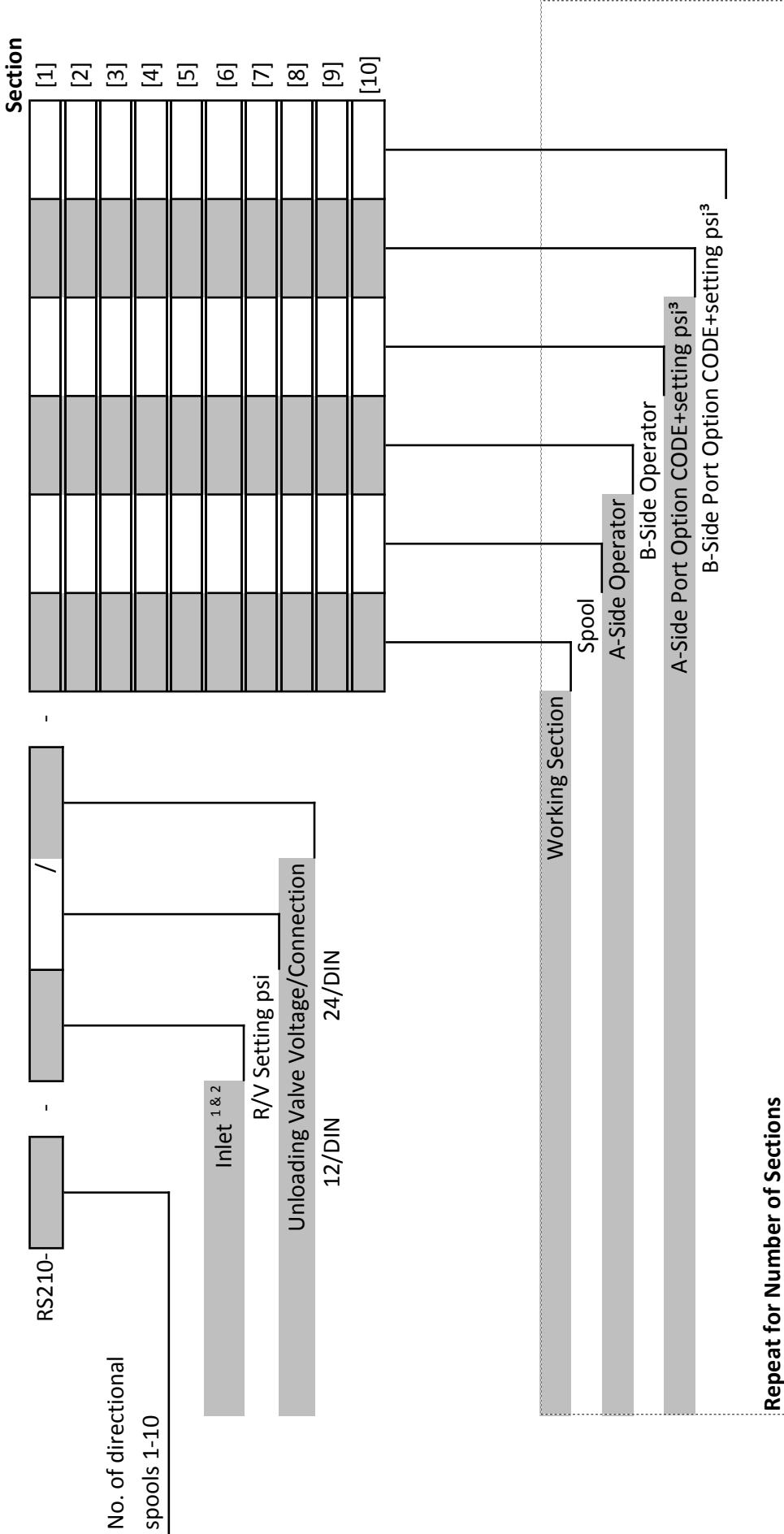

Repeat for Number of Sections

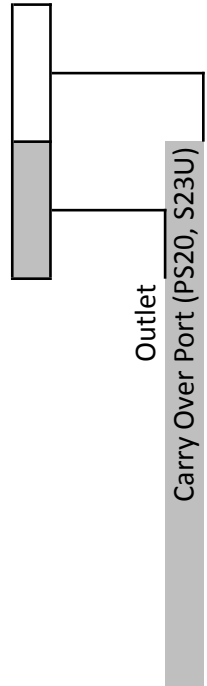

Application Information

OEM: _____
 Machine Type: _____
 Pump Type: _____
 Pump Flow: _____
 System Pressure: _____
 EAU: _____
 Other Information: _____

1] Standard inlet is I04B; corresponding outlet is U05B
 2] Q-Inlet components (R/V type, Q cartridge, Q orifice) are selected by HYDAC based upon all other details of valve specification.
 3] i.e. TBSD121 + 3,000 psi

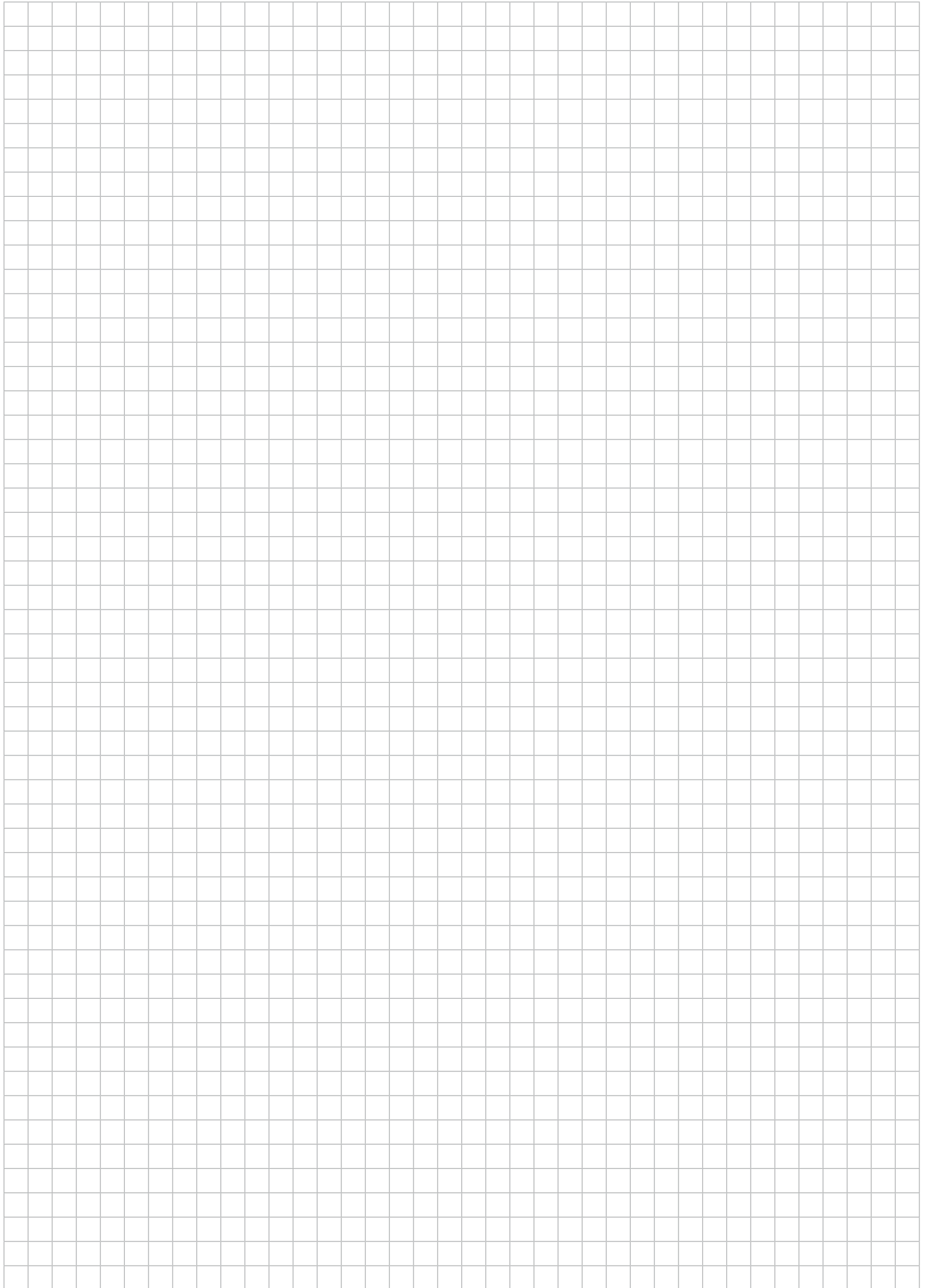

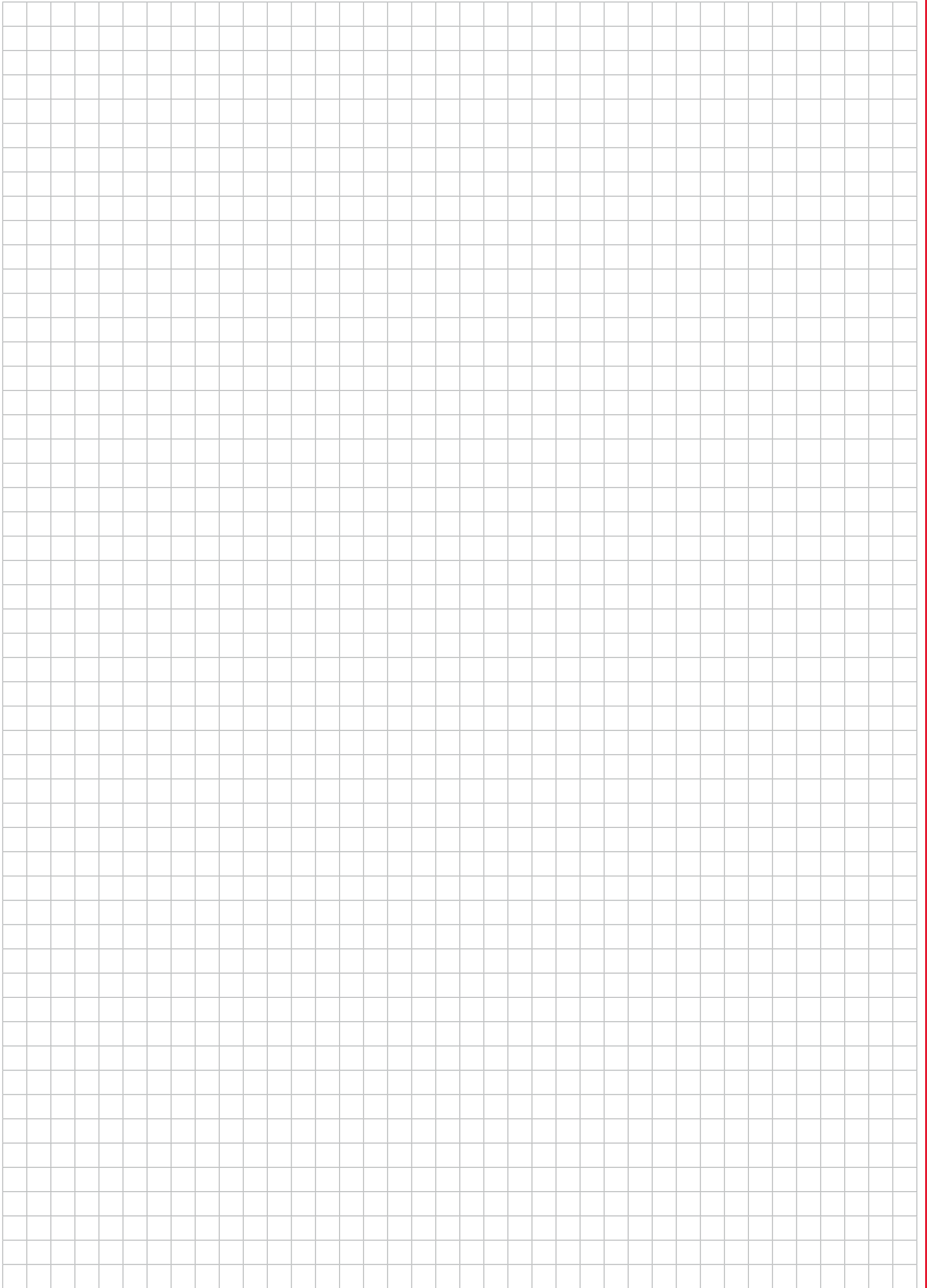

HYDAC INTERNATIONAL

Global Head Office
HYDAC INTERNATIONAL
GMBH

Industriegebiet
D – 66280 Sulzbach/Saar
Germany

Tel.: +49 6897 509-01

Fax: +49 6897 509-577

Internet: www.hydac.com
Email: info@hydac.com

HYDAC North America Locations

USA

www.HYDACusa.com

HYDAC TECHNOLOGY CORPORATION Filter Division

2260 City Line Road
Bethlehem, PA 18017

+1.610.266.0100

HYDAC TECHNOLOGY CORPORATION Accessory Division

2204 Avenue C
Bethlehem, PA 18017

+1.610.266.0100

HYDAC TECHNOLOGY CORPORATION Electronic Division Process Filter Division

HYDAC CORPORATION Accumulator Division

90 Southland Drive
Bethlehem, PA 18017

+1.610.266.0100

HYDAC TECHNOLOGY CORPORATION Cooling System Division

445 Windy Point Drive
Glendale Heights, IL 60139

+1.630.545.0800

HYDAC TECHNOLOGY CORPORATION Hydraulic Division - Compact Hydraulics

450 Windy Point Drive
Glendale Heights, IL 60139

1749 Paul Avenue
Glendale Heights, IL 60139

+1.630.545.0800

HYDAC TECHNOLOGY CORPORATION Mobile Hydraulic Division

1660 Enterprise Parkway • Suite E
Wooster, OH 44691

+1.610.266.0100

HYDAC TECHNOLOGY CORPORATION Cooling System Division

1051 Airlie Parkway
Denver, NC 28037

+1.610.266.0100 x1805

HYDAC Cylinders LLC

540 Carson Road North
Birmingham, AL 35217

+1.205.520.1220

HYDAC TECHNOLOGY CORPORATION HYDAC CORPORATION Sales Office & Operations

1718 Fry Road, Suite 100
Houston, TX 77084

+1.281.579.8100

HYDAC TECHNOLOGY CORPORATION HYDAC CORPORATION NE Sales Office

1660 Enterprise Parkway • Suite E
Wooster, OH 44691

+1.610.266.0100

HYDAC TECHNOLOGY CORPORATION HYDAC CORPORATION SE Sales Office

1051 Airlie Parkway
Denver, NC 28037

+1.610.266.0100 x1805

HYDAC TECHNOLOGY CORPORATION HYDAC CORPORATION NW Sales Office

1201 NE 144th Street
Suite 111

Vancouver, WA 98682

+1.610.266.0100

Canada

www.HYDAC.ca

HYDAC CORPORATION

14 Federal Road
Welland, Ontario, Canada L3B 3P2

+1.905.714.9322

HYDAC CORPORATION Sales Office

Montreal, Québec, Canada J2M 1K9

+1.877.539.3388

HYDAC CORPORATION Sales Office

101 - 18207 114 AVE W
Edmonton, Alberta, Canada T5S 2P6

+1.780.484.4228

Mexico

www.HYDACmex.com

HYDAC INTERNATIONAL SA DE CV

Calle Alfredo A. Nobel #35
Colonia Industrial Los Reyes
Tlalnepantla, CP. 54075
Edo. de Mexico

+011.52.55.47771262

Note

The information in this brochure relates to the operating conditions and applications described.

For applications or operating conditions not described, please contact the relevant technical department.

Subject to technical modifications.