

## Sectional Directional Control Valve RS 280



### Key valve features

RS 280 is a sectional valve designed for max. operating pressures up to 275 bar and max. pump flows up to 120 l/min.

It is available with 1 to 10 working sections per valve assembly.

RS 280 is designed with an open center for fixed displacement pumps.

The valve can be operated manually, by pneumatic, electro-pneumatic or hydraulic remote control.

The valve offers excellent operating characteristics because of the specially designed spools for different applications.

Low and uniform spool forces are the result of careful balancing of the flow forces.

### Applications

Typical applications for RS 280 are cranes, tippers, truck loaders, backhoe loaders and wheel loaders.

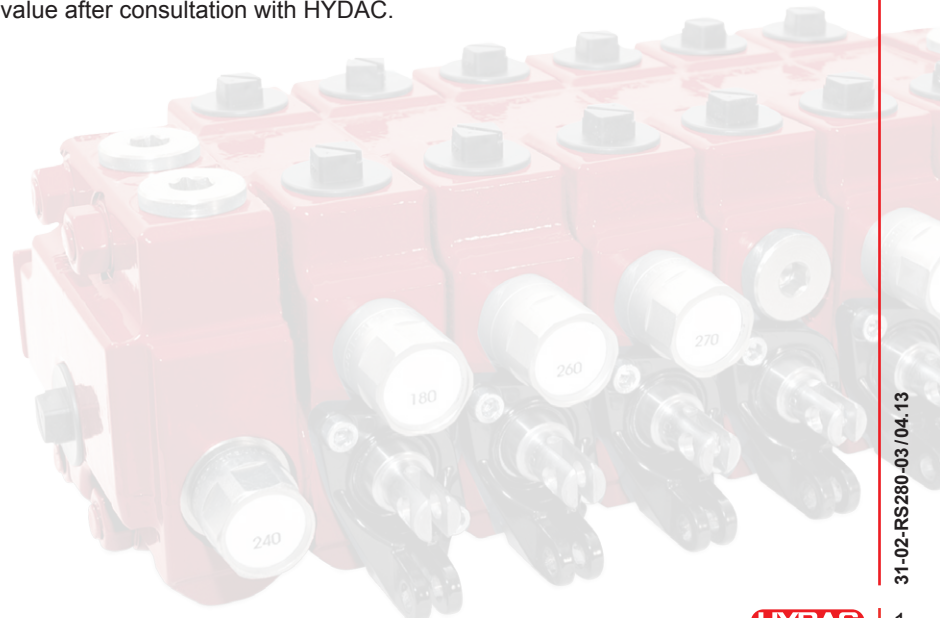
### Further RS 280 properties and possibilities

- Many varieties of spools and spool controls make the valve suitable for a wide range of applications
- Each section can be provided with a pressure relief valve, an anti-cavitation valve or a combination of these
- Possibility of high pressure carry-over
- With combination of an intermediate section there is the opportunity to realize different system alternatives, for example dual pump circuits, built in one compact valve

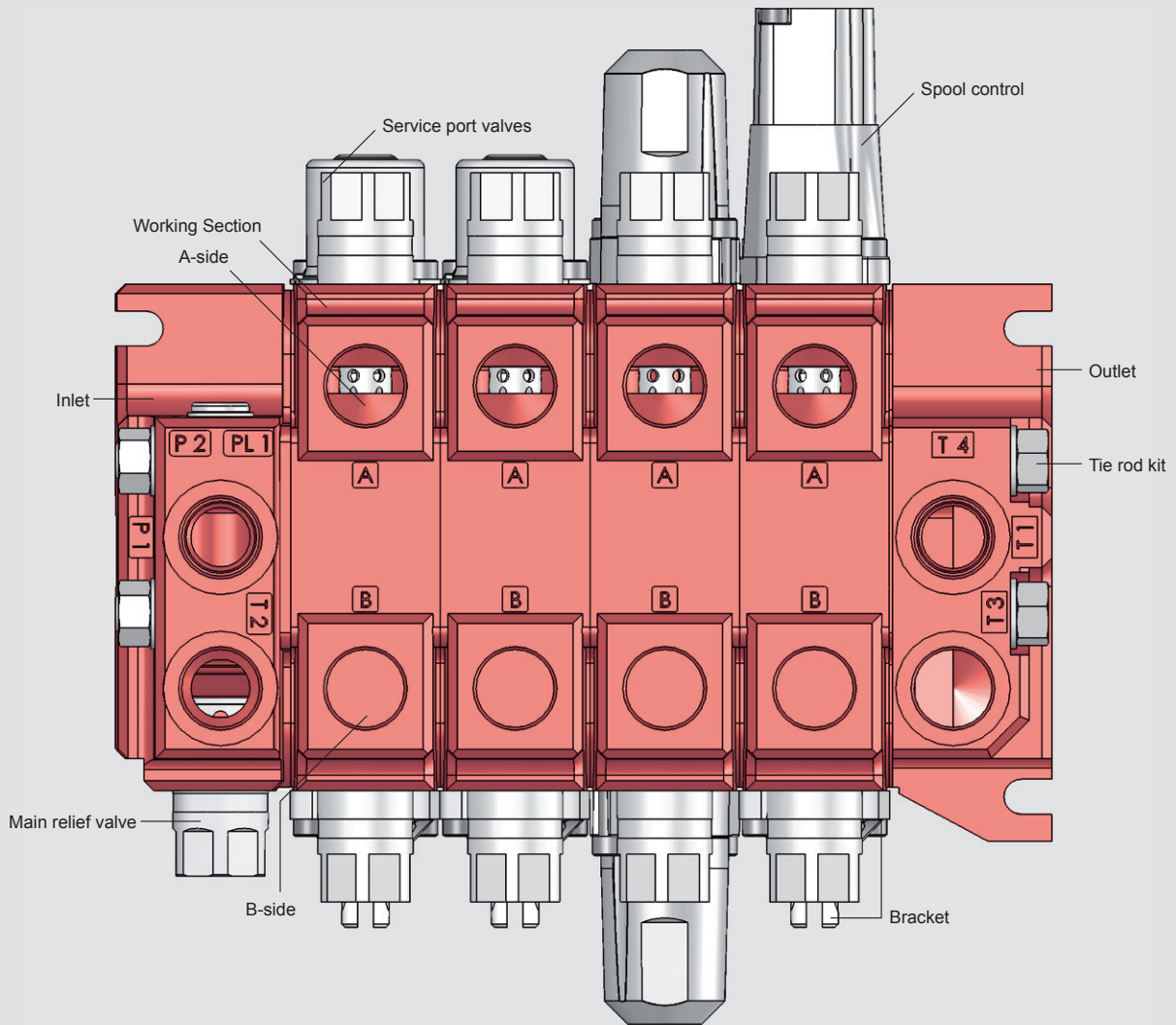
### Technical data

Pressures / Flow	
Max. operating pressure per port:	
P1, P2, PL1, A, B:	275 bar
T1, T2, T3, T4:	20 bar
Max. permissible flow either on port P1, P2 or PL1:	
120 l/min	
Fluid temperature range:	
-15 °C up to +80 °C	
Further data	
Spool stroke:	
Nominal:	+/- 8 mm
4:th position:	+ 15 mm
Spool control force spool control 9:	
Neutral position:	110 N
Max. spool stroke:	140 N
Detent in:	>425 N
Detent out:	<225
Permissible contamination level:	
Equal or better than 20/18/14 as per ISO 4406	
Viscosity range:	
10 – 400 mm <sup>2</sup> /s (cst) Higher viscosity allowed at start up	
Leakage A, B → T at 100 bar, 32 cst and 40 °C: ≤18 cc/min	
Pressure fluid:	
Mineral oil and synthetic oil based on mineral oil HL, HLP according to din 51524	

Higher values are possible, depending on application. For applications with demands that exceed stated data above, please contact us for consideration.  
MTTFd value after consultation with HYDAC.

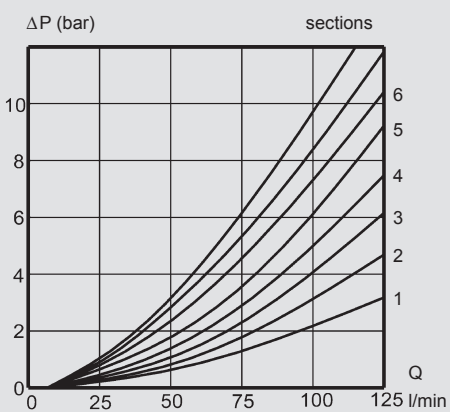


## General overview

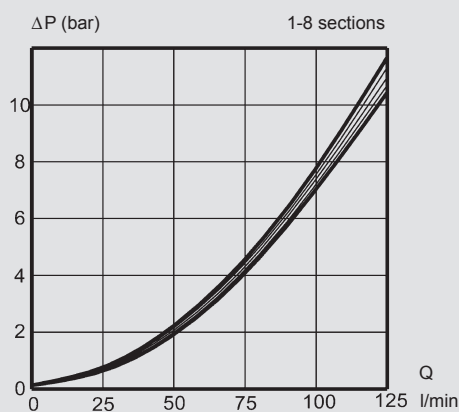


## Pressure drop

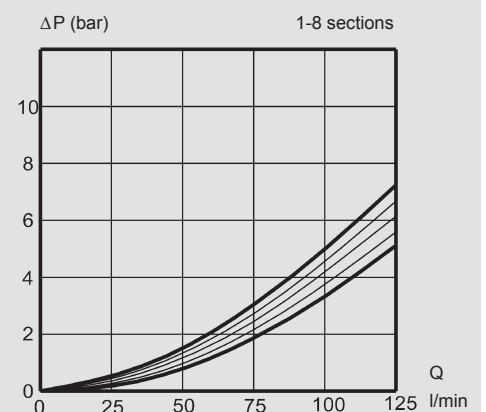
Oil temperature / viscosity for all graphs: +40 °C / 32 cSt



Pressure drop P – T

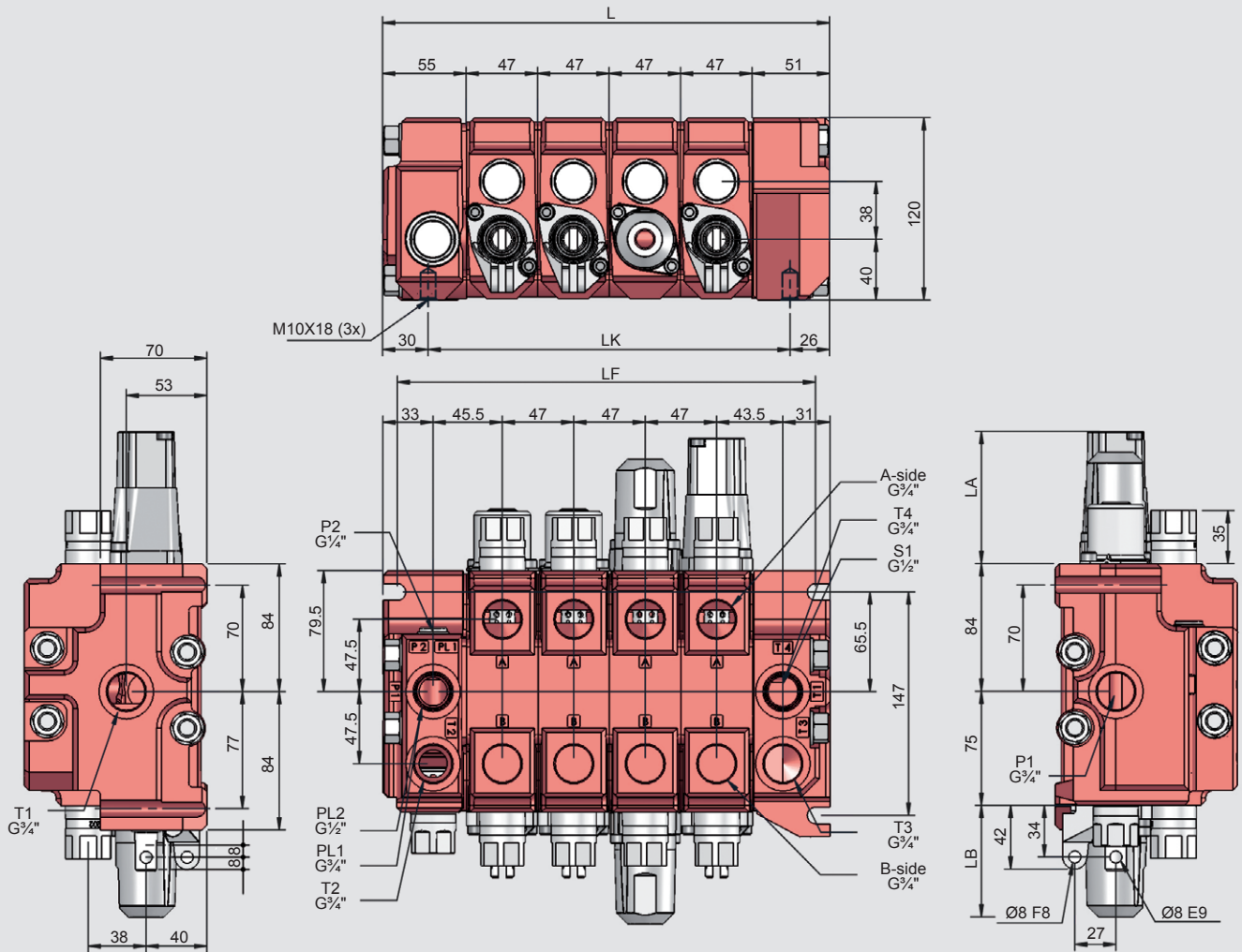


Pressure drop P – A/B



Pressure drop A/B – T

## Dimensions and Weight



### Weight

Inlet section	4.4 kg
Outlet section	5.0 kg
Working section	5.0 kg
Intermediate section	4.4 kg

No. of sections	L [mm]	LF [mm]	LK [mm]
1	153	134	97
2	200	181	144
3	247	228	191
4	294	275	238
5	341	322	285
6	388	369	332
7	435	416	379
8	482	463	426
9	529	510	473
10	576	557	520

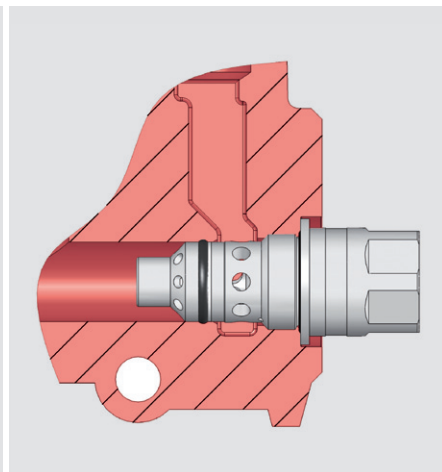
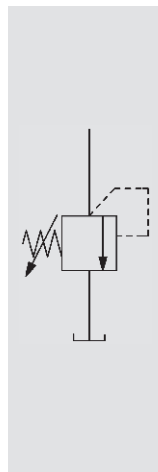
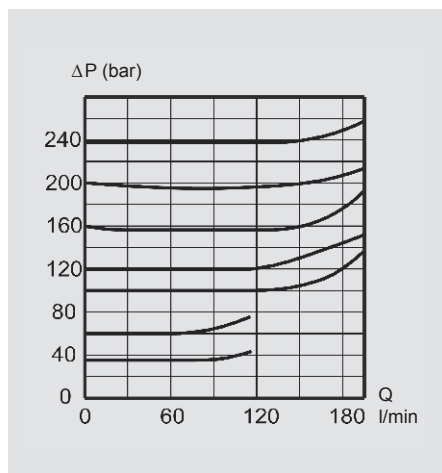
Type	LA [mm]	Type	LB [mm]
910	40.5	M1	42
10	87	M2	15
11	87	M3	52
13	87	3W	92
14	87	4W	102
L81-83	105	HPD1B	72
P	103		
EP	134		
HPD1A	72		
HPD405	107.5		

## Main relief valves

### Main relief valve TBD201

The TBD201 is a differential area, direct acting relief valve, for the main circuit. It is adjustable and sealable.

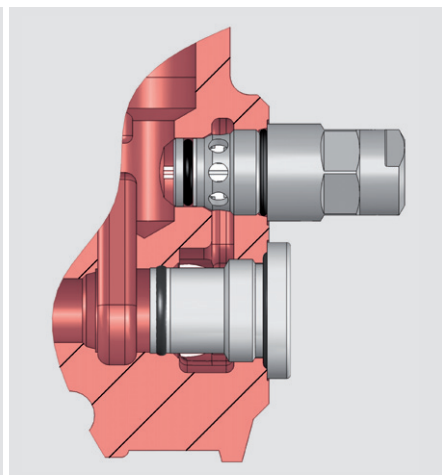
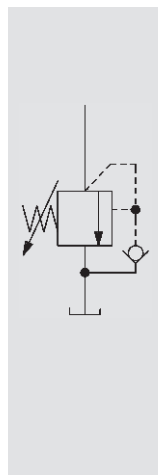
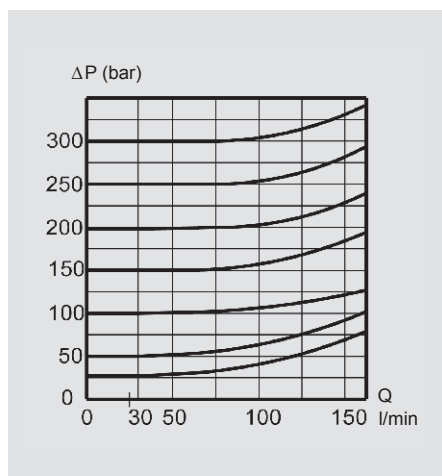
- Setting range:  
35 – 275 bar  
(3.5 – 27.5 MPa)
- Setting range step: 5 bar



### Main relief valve TBS400

Pilot operated relief valve for the intermediate section. It is adjustable and sealable.

- Setting range: 35 – 275 bar  
(3.5 – 27.5 MPa)
- Setting range step: 5 bar

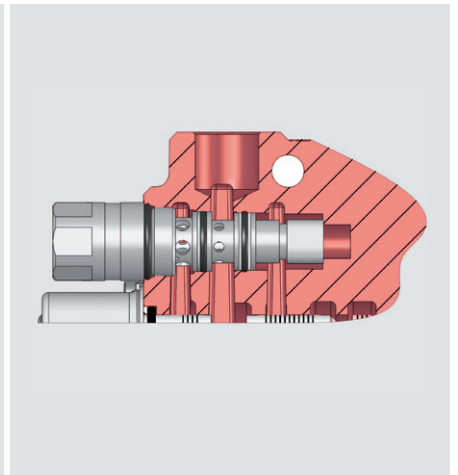
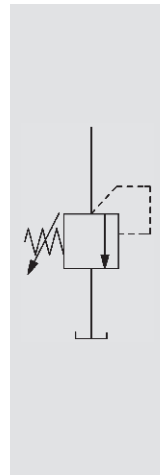
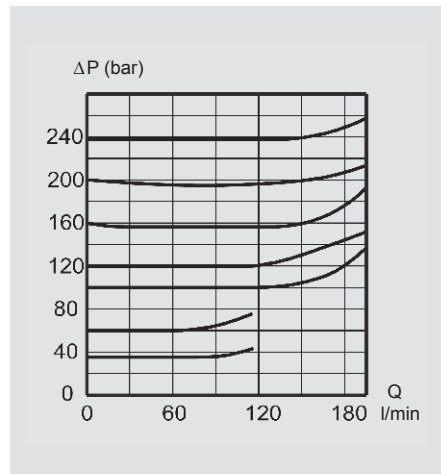


## Service port valves

### Port relief valve TBD202

The TBD202 is a differential area, direct acting relief valve for the secondary circuit.

- Setting range:  
35 – 275 bar  
(3.5 – 27.5 MPa)
- Setting range step: 5 bar



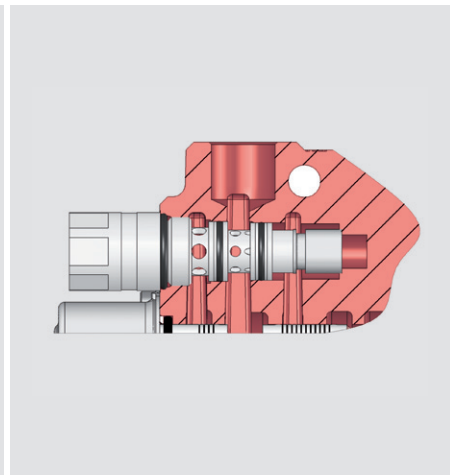
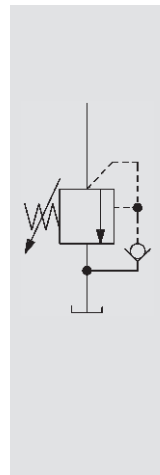
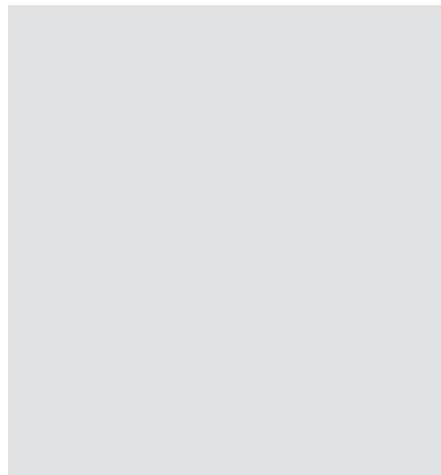
### Port relief and anticavitation valve TBSD202

Characteristics: See particulars of the port relief valve and the anticavitation valve.

The TBSD202 is a differential area, direct acting relief and anticavitation valve, for the secondary circuit.

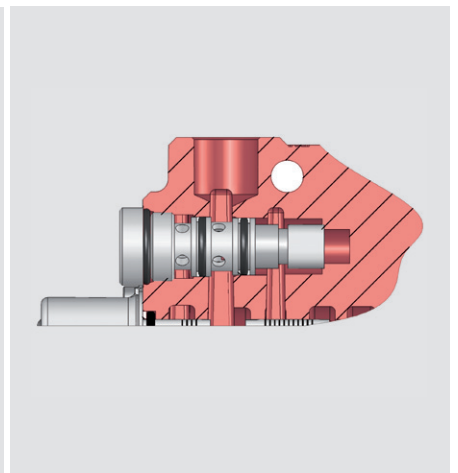
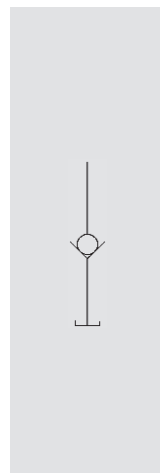
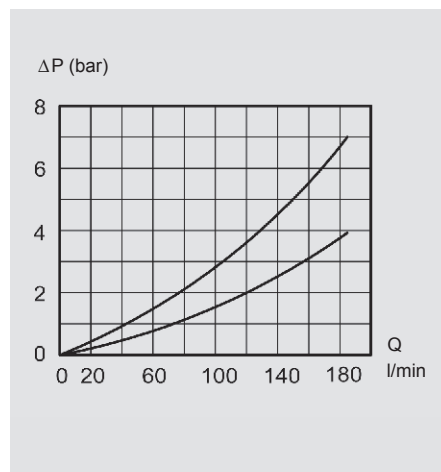
It is adjustable and sealable.

- Setting range: 35 – 275 bar  
(3.5 – 27.5 MPa)
- Setting range step: 5 bar



### Anticavitation valve SB250

The anticavitation valve service to ensure that, in the event of a lower pressure in the cylinder port than in the tank, oil can be drawn from the system oil tank to the consumer.



## Spool controls – A-side

<b>Spool control 9</b>	
9 Spring centered	
<b>Spool control 10</b>	
Detents at positions 1, 2 and 3	
<b>Spool control 11</b>	
Spring centering with detent at position 4	
<b>Spool control 13</b>	
Spring centering with detent at position 2	
<b>Spool control 14</b>	
Spring centering with detent at position 3	
<b>Spool control P</b>	
Pneumatic*	
<b>Spool control EP</b>	
Electro / pneumatic on / off**	
<b>Spool control HPD1</b>	
Hydr. proportional Pilot pressure: 6 – 16 bar Max. pilot pressure: 25 bar***	
<b>Spool control HPD405</b>	
Hydr. proportional spool control with float in 4th position***	
<b>Spool control L81</b>	
External hydraulic kick-out from inserted spool***	
<b>Spool control L82</b>	
External hydraulic kick-out from extended spool***	
<b>Spool control L83</b>	
External hydraulic kick-out from inserted and extended spool***	

\* Connection G 1/8" BSP

\*\* Power consumption 4.8 W

Rated voltage 24 V

Max voltage variation +/- 10 %

Duty factor 100 %

Connection according to

EN175301-803/B

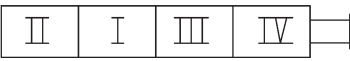
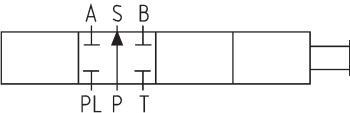
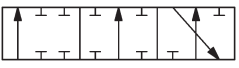
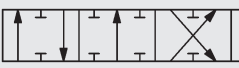
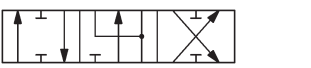
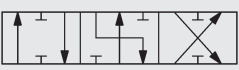
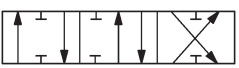
Protection class IP65

\*\*\* Connection G 1/4" BSP

## Spool controls – B-side

<b>Bracket M1</b>	<b>3W</b>
Bracket for 3-position spool	Cap for 3-position spool controlled by cable
<b>Bracket M2</b>	<b>4W</b>
Bracket for 3-position spool, without ear	Cap for 4-position spool controlled by cable
<b>Bracket M3</b>	
Bracket for 4-position spool	

## Spools

	Spools for general use	
	Function	Code
	Double acting spool	1X
	Single acting spool P – B	2X
	Double acting spool with 4th pos. for float	3X
	Motor spool	4X
	Motor spool A – T	4XA
	Motor spool B – T	4XB

The RS 280 spools are available in variety of flows and styles to accommodate most design requirements. Since the development of spools is a continuous process and all available spools are not described in this data sheet, contact Hydac for advice on choosing spools in order to optimize your valve configuration.

Generally the spools are divided in 6 different flow ranges. The letter indicating flow ranges is replaced by X.

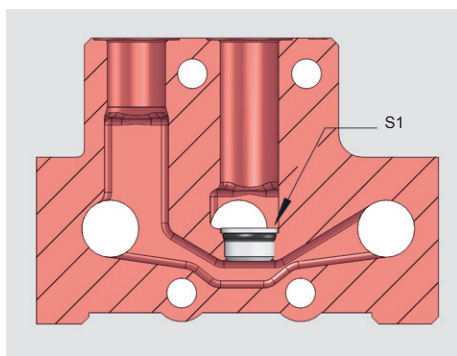
D = 60 l/min, F = 70 l/min, H = 80 l/min, G = 90 l/min, K = 120 l/min.

In the table only the accessibility of different functions are shown.

## High pressure carry-over

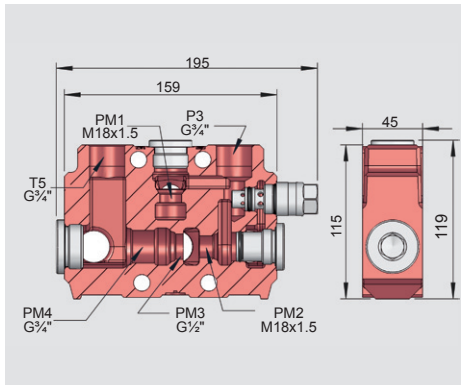
### High pressure carry-over plug PS28

Plug PS28, mounted in S1 allows a high pressure carry-over function.



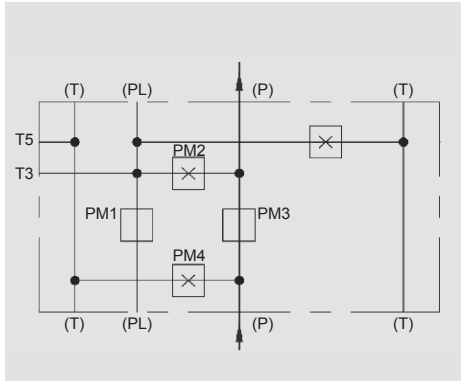


## System alternatives with intermediate section



The intermediate section allows a number of different internal and external system alternatives.

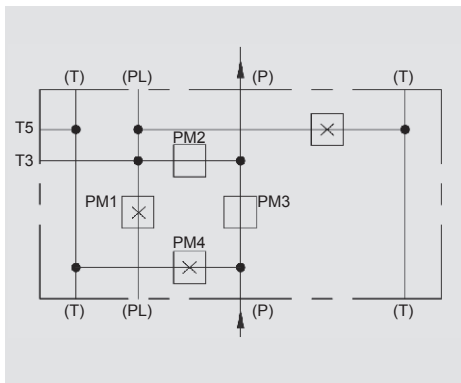
Existing valve equipped with the intermediate section can easily be altered to other system configurations without dismantling the valve.



### K1, Single circuit

Valve internally parallel coupled.

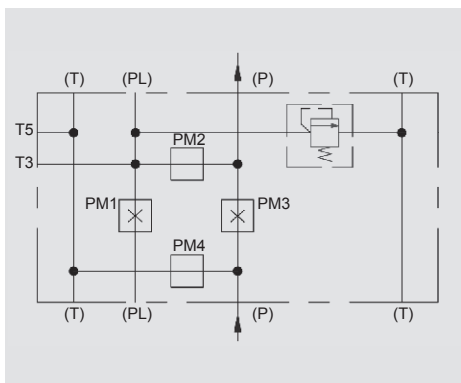
Main relief valve for the system can be positioned in the intermediate section.



### K2, Single circuit

Valve internally tandem coupled, i. e. working sections upstream of the intermediate section with fully selected spools have complete priority as far as flow supply is concerned in relation to working sections downstream of the intermediate section.

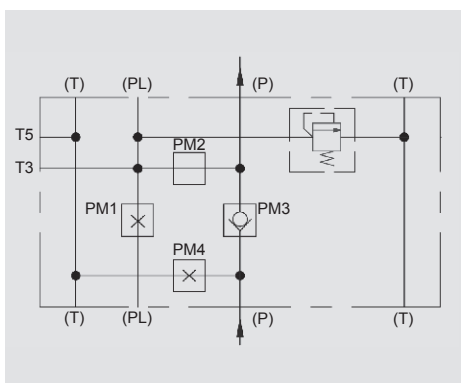
A second main relief valve, positioned in the intermediate section, can be used to reduce the pressure to working sections downstream from the intermediate section.



### K3, Dual circuit

The intermediate section divides the valve into two completely separated circuits. The tank gallery is common.

Multicircuit operation is possible according to the same pattern.



### K5, Dual circuit

Tandem coupling between first and second circuit.

The first circuit is always solely supplied from the first pump.

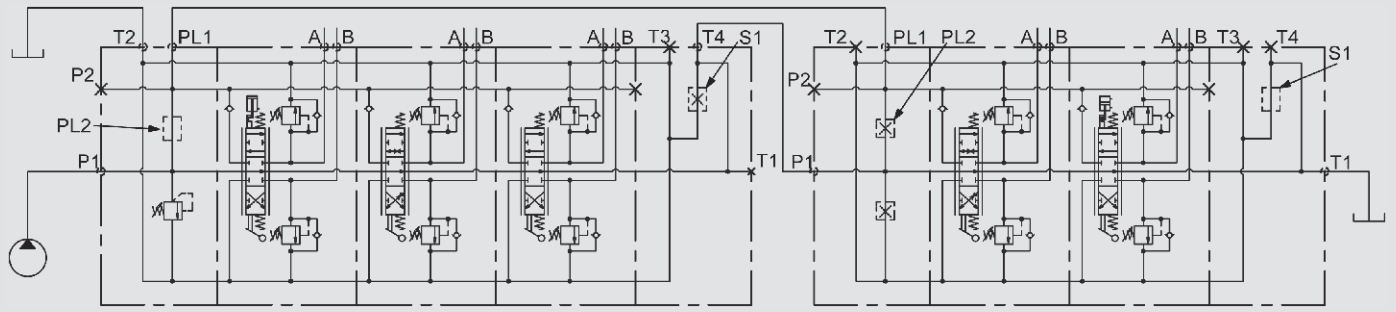
The second circuit is always supplied from the second pump.

When the first circuit is inactive then the second circuit is supplied from both pumps.

Multicircuit operation is possible according to the same pattern.

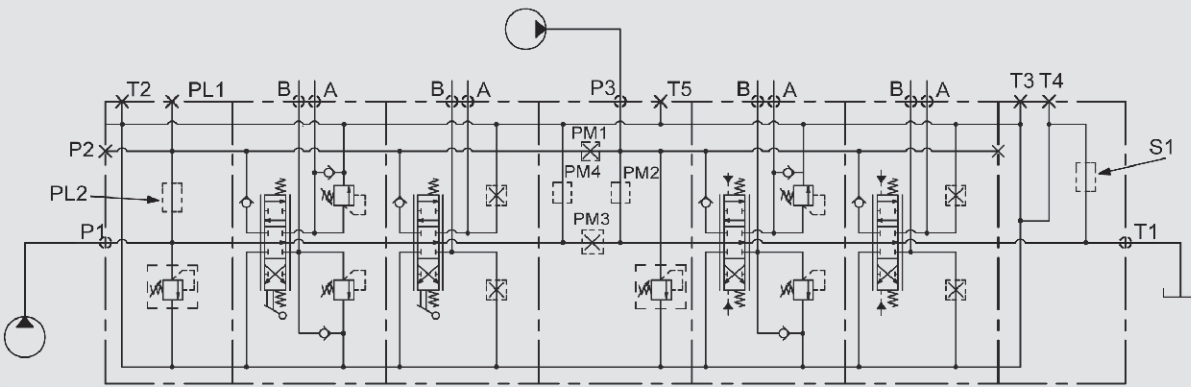


## Typical hydraulic circuit diagrams

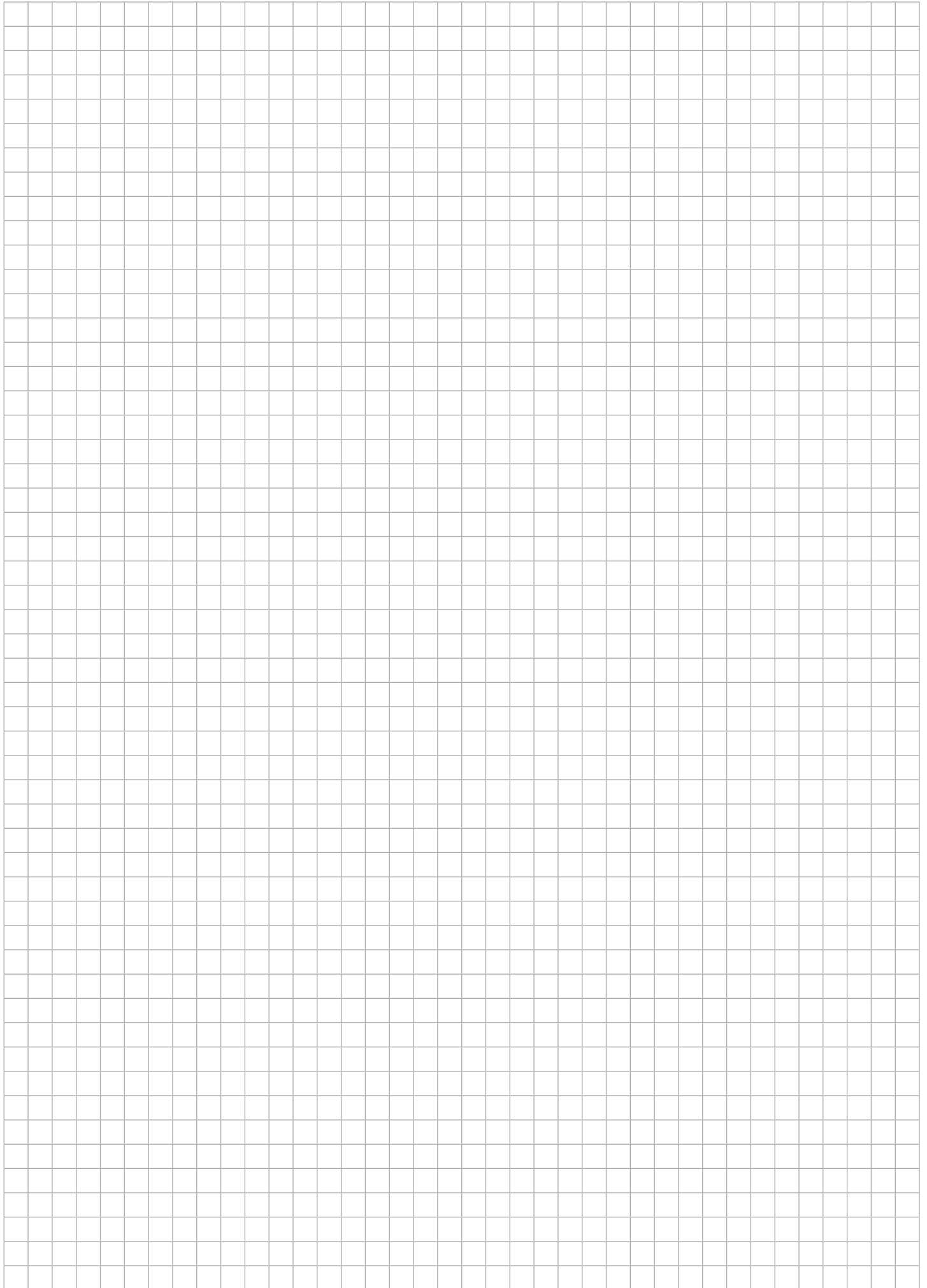


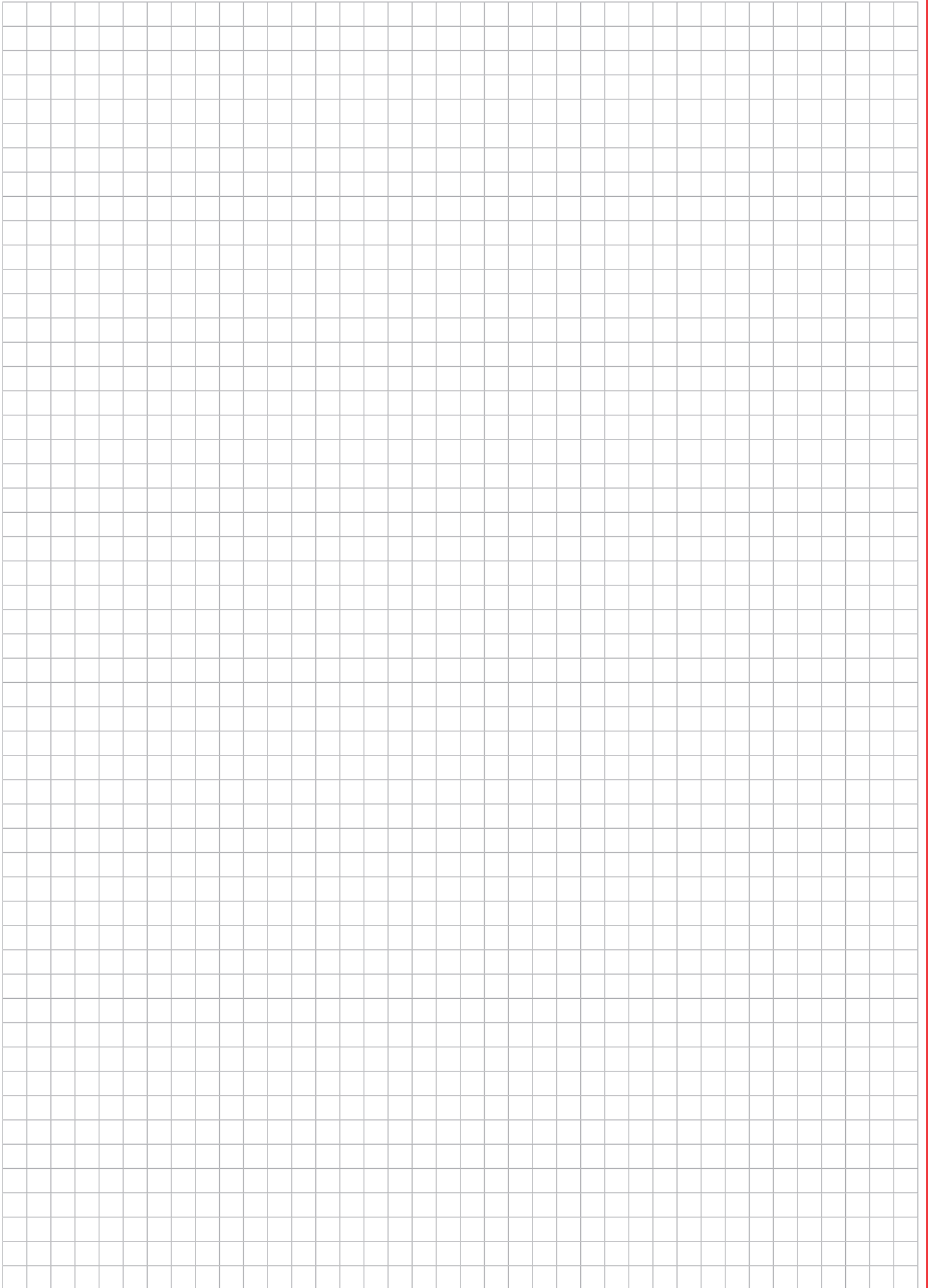
**Diagram 1: High pressure carry-over**

In parallel connection the same pump is connected to two or more valves. The function is the same as if the pump was connected to one large valve.



**Diagram 2: Two pump circuit with intermediate section (K3)**





## Note

The information in this brochure relates to the operating conditions and applications described.

For applications or operating conditions not described, please contact the relevant technical department. Subject to technical modifications.



**Nordhydraulic**  
HYDAC INTERNATIONAL

Head Office  
HYDAC INTERNATIONAL  
GMBH

Industriegebiet  
66380 Sulzbach/Saar  
Germany

Phone: +49 6897 509-01  
Fax: +49 6897 509-577

E-mail: [mobilevalves@hydac.com](mailto:mobilevalves@hydac.com)  
Internet: [www.hydac.com](http://www.hydac.com)