



RSQ 240 Series

Directional Control Valve

Summary of North American Offering

INLETS *(Schematics per data sheets except SAE ports)*

Type I11D in SAE P1, T1 (SAE-12), PPM (SAE-4)

Type I21A in SAE T1 (SAE-16), P1 (SAE-12), P2 (SAE-10)

Type I21B in SAE T1 (SAE-16), P1 (SAE-12), P2 (SAE-10)

WORKING SECTIONS *(Schematic per data sheets except SAE ports)*

Type S11B, S11C in SAE A, B (SAE-10)

OUTLETS *(Schematic per data sheets except SAE ports)*

Type U21A in SAE. T2 (SAE-16), T4 (SAE-10)

Type U21B in SAE. . . T2 (SAE-16), T3, PPM (SAE-8), T4 (SAE-10)

INTERMEDIATE OUTLET *(Schematic per data sheets except SAE ports)*

Type U21C in SAE. T2 (SAE-16), PPM (SAE-8), T4 (SAE-10)

Spools Most Available

Type 112,114,116,119, 219, 412, 414, 416, 419, 314

Spool Controls Most Available

Hydraulic pilot, manual lever, electro-hydraulic (EHP),
electrical on/off

Other options available *(check with factory for leadtimes)*

1.877.GO.HYDAC | www.HYDACusa.com

1.888.99.HYDAC | www.HYDAC.ca

HYDAC TECHNOLOGY CORPORATION
Mobile Hydraulic Division

1660 Enterprise Parkway • Suite E
Wooster, OH 44691

+1.610.266.0100 ext 1902

Make use of the Nordhydraulic expertise

Our skilled and experienced design and application engineers are at your disposal, helping you to specify the valve configuration that meets your application requirements.

With the RSQ 240 Nordhydraulic is pioneering the development of open centre valve designs with a unique, patented, product.

Key valve features

RSQ 240 is a sectional, parallel circuit valve, designed for system pressures up to 350 bar and pump flows up to 140 l/min.

It is available with 1 to 10 working sections per valve assembly.

RSQ 240 is designed with an open centre for fixed and variable displacement pumps.

RSQ 240 is characterised by the unique dual flow range possibility and its ability to facilitate simultaneous operation of several functions.

It is available with electro-hydraulic or hydraulic proportional remote control, but the valve can also be manually operated.

The electro-hydraulic proportional version in particular offers compact design with internal pilot oil supply, solenoids integrated in the valve body and integral hand levers for manual override/manual operation.

The valve offers excellent operating characteristics because of the specially designed spools for different applications.

Low and uniform spool forces are the result of careful balancing of the flow forces.

Q-function

The flow control (Q-function) of the inlet section bypasses the major part of the pump flow to tank when the system is idling, thereby greatly reducing heat generation. But it also gives access to the full pump flow when the services are operated and provide improved operating characteristics.

Q-function, in combination with the dual parallel gallery functional principle unique for RSQ 240, and separate flow regulation in each working section, gives this valve a very high performance level.

Applications

The RSQ is ideal for applications such as truck cranes, backhoe-loaders, excavators, drilling rigs, telescopic

load handlers, sky-lifts, refuse vehicles and fork lift trucks.

Remote control

The RSQ 240 is designed with an integrated pilot supply system in order to achieve an easy installation and a reliable remote control function. It is also possible (and in some cases to prefer) to supply the pilot system externally.

Further RSQ 240 properties and possibilities

- Complete flow regulation control. At reduced flow the entire spool (lever) resolution is maintained.
- Raised working pressure level in low flow mode allowing increased pay-loads, for example in cranes.
- Separate adjustable flow limitation in each section, independent of pump flow.
- A wide choice of spools and spool controls for different flow combinations and for several applications and systems.
- A full range of service port valves.
- Load check valves in each working section.
- Spool actuators for external kick-out and spool position sensing.
- L. h. and r. h. inlet configurations are available.
- Intermediate outlet section for dual circuit systems.
- Easily convertible for systems with variable pump.
- Manual versions easily convertible to remote control.
- Pressure relief valve for downstream services.
- Electrical unloading.
- Regenerative function.
- Possibility of high pressure carry-over.

Data sheet

This data sheet presents a selection of standard components and how to specify these in a valve assembly according to your application requirements. For further information on RSQ 240 and available components, please contact Nordhydraulic.



Table of contents

Dimensions, weightpage 4, 6 - 7
Technical datapage 5
Inlet sections.....page 7 - 8
Working sections.....page 9
Outlet sectionspage 10 - 11
El. unloading, two speed control.....page 12
Spool controls, Lever.....page 13
Solenoid valve EHPpage 14
Spools.....page 15
Relief valves.....page 16 - 18
Miscellaneous.....page 19
Hydraulic diagrams.....page 20

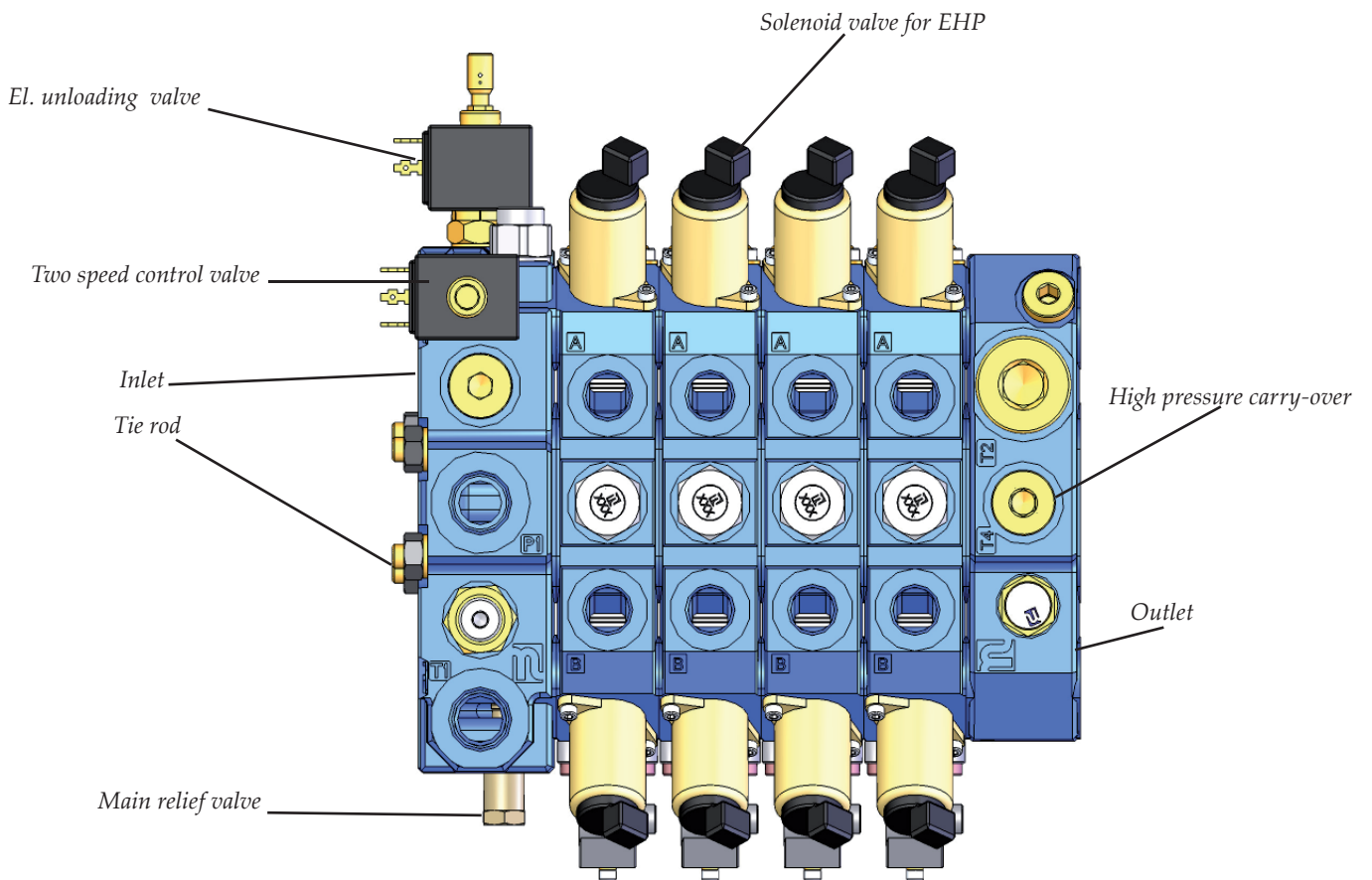

Technical data - weight - dimensions

Pressures / flow

Max. system pressure*350 bar (35,0 MPa)
 Max. continuous return line pressure..... 20 bar (2,0 MPa)
 Max return line pressure, pilot oil circuit5 bar (0,5 MPa)
 Rated pump flow** 120 l/min
 Max. recommended flow per section 100 l/min

* Depending on application
 ** Pump flows above 100 l/min may require metering check valve MF24 in working sections

Further data

Spring force for spool control 901 in neutral position: 110 N (11,0 kp).

Spring force for spool control 901 with fully selected spool: 130 N (13,0 kp).

Recommended contamination level at normal duty: equal to or better than 18/14 as per ISO 4406.

At high system pressure and/or for remote control: equal to or better than 17/13 as per ISO 4406.

Hydraulic fluid viscosity range: 10-400 mm²/s (cSt). Higher viscosity allowed at start up.

Mineral oil and synthetic oil based on mineral oil are recommended.

Max hydraulic fluid temperature range for continuous operation: -15°C - +80°C.

Spool leakage at 100 bar, 32 cSt and 40°C: < 13 cm³/min.

Attention:
 To ensure proper function of remote control systems it is very important that the acceptable level of contamination is not exceeded.

Weight

Inlet section	Weight kg
I11D	8,2
I21A	6,2
I21B	6,1

Outlet section	Weight kg
U21A	6,0
U21B	5,9
U21C	5,8

Working section	Weight kg
S11B	5,6
S11C	5,5

Dimensions, spool controls

Type	LA mm	LB mm
901	27	
1001	64	
1101	64	
HP04	32	
HP02	70	
L61	87	
L64	91	
HL61	87	
HL64	96	
LE11	85	
M01		38
MP03		70
MH02		57
MH03		57





Technical data

Oil temperature/viscosity for all graphs: + 50°C / 32 cSt

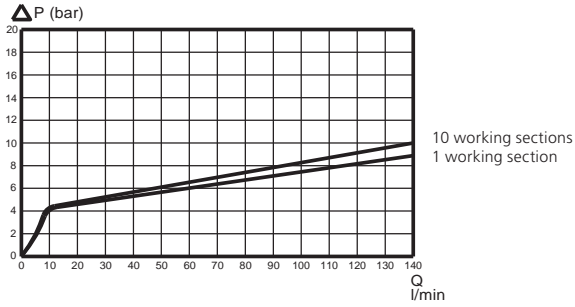

Pressure drop el. unloaded, with PF505, FK501

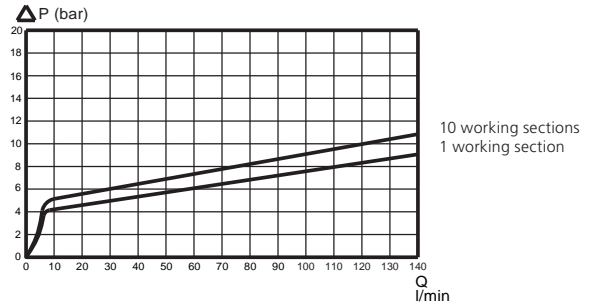

Pressure drop P - T (idling), with PF505, FK501

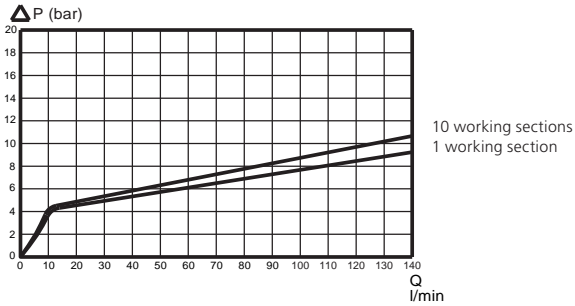

Pressure drop el. unloaded, with PF507, FK502

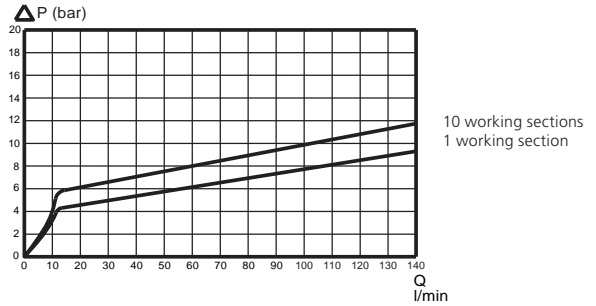

Pressure drop P - T (idling), with PF507, FK502

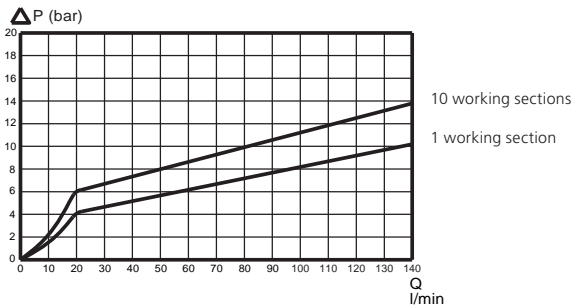

Pressure drop El. unloaded, with PF511, FK505

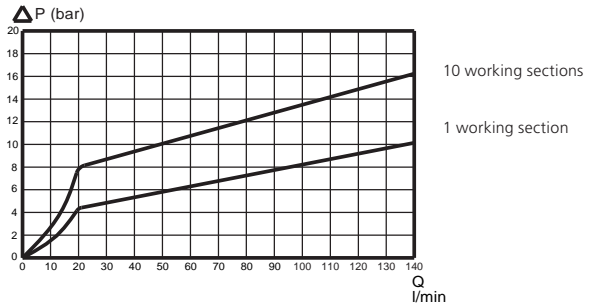

Pressure drop P - T (idling), with PF511, FK505

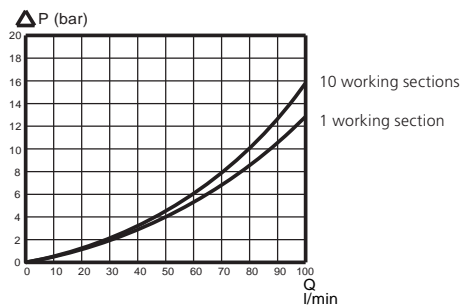

Pressure drop P-A/B

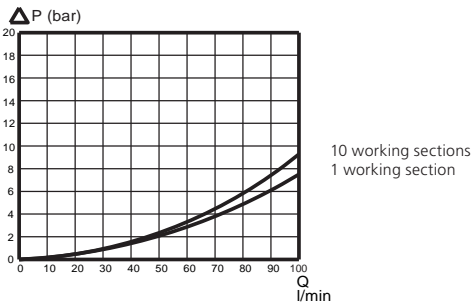

Pressure drop A/B - T

Dimensions

I11D

U21B

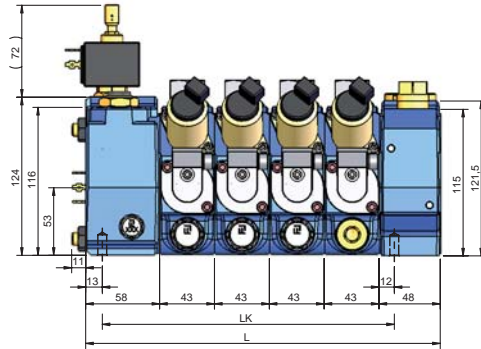

No. of sections	L mm	LK mm
1	149	100
2	192	143
3	235	186
4	278	229
5	321	272
6	364	315
7	407	358
8	450	401
9	493	444
10	536	487

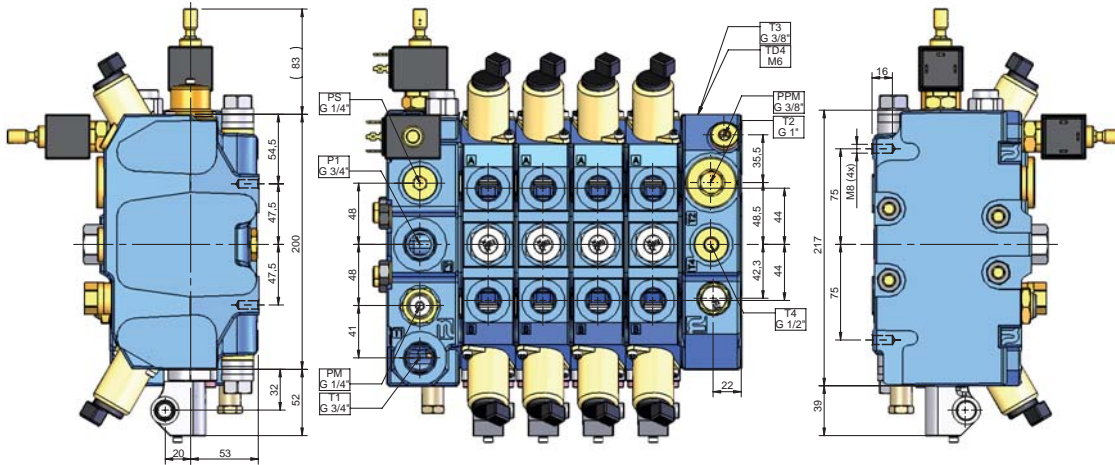

I21A

U21A

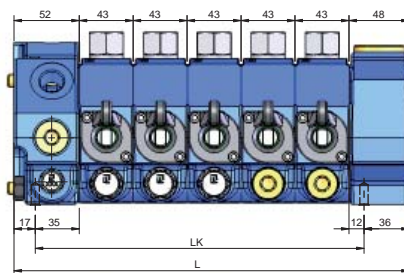

No. of sections	L mm	LK mm
1	143	90
2	186	133
3	229	176
4	272	219
5	315	262
6	358	305
7	401	348
8	444	391
9	487	434
10	530	477

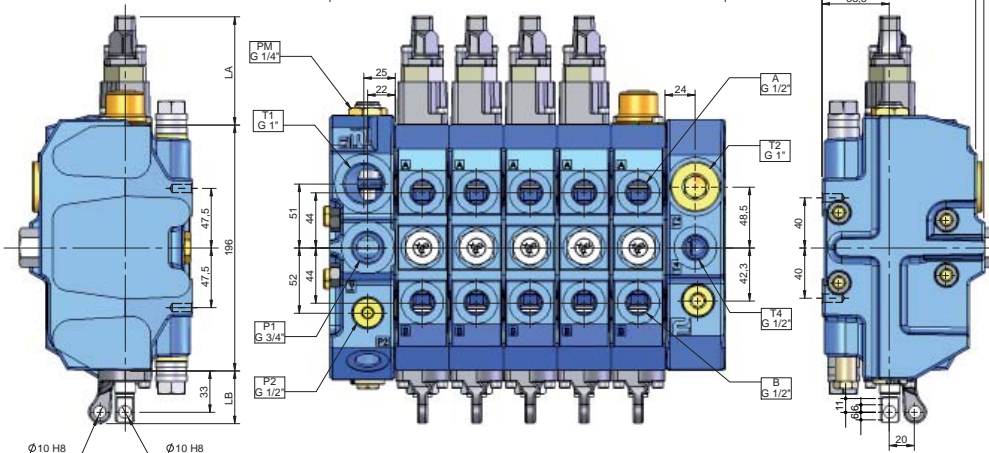



Dimensions

RSQ 240

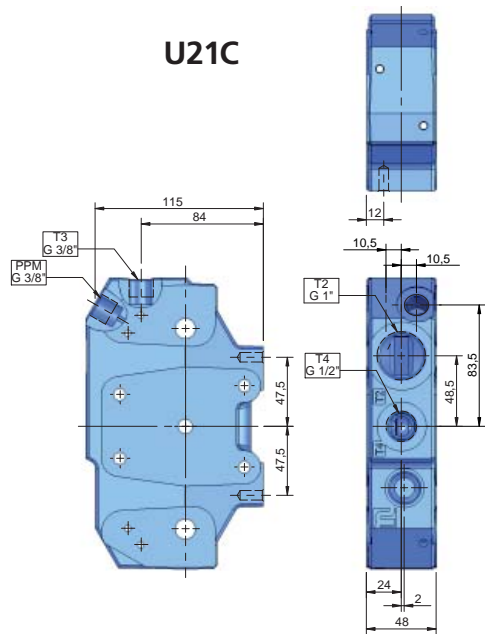

Inlet section I11D - dual flow ranges

The unique RSQ 240 high – low flow property is achieved by the integral switching spool of I11D, which can be electrically operated by the use of an E926 valve.

The I11D with its integral Q-function provides by-pass of pump flow to tank in idling condition thereby reducing pressure drop and heat generation, as well as accomplishing improved control characteristics.

The by-pass flow control spool in combination with an el. unloading valve (E926) achieves emergency dump of all pump oil to tank.

I11D houses a small relief valve cartridge TB12 which together with the by-pass flow control spool provides the primary relief valve function of the RSQ 240. A choice of different metering orifice cartridges are available, determining low flow range, influencing pressure build-up to suit different applications and constituting flow from the high pressure carry-over for downstream services.

I11D when equipped with a pressure reducing cartridge TRA53, provides pilot oil supply for hydraulic and electro-hydraulic proportional remote controlled working sections.

I11D is equipped with a special check valve, FSB4, to cushion the opening of the by-pass control spool thereby eliminating unnecessary pressure peaks.

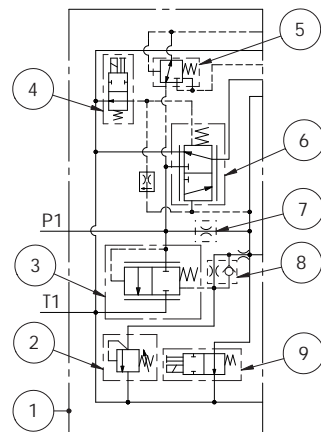
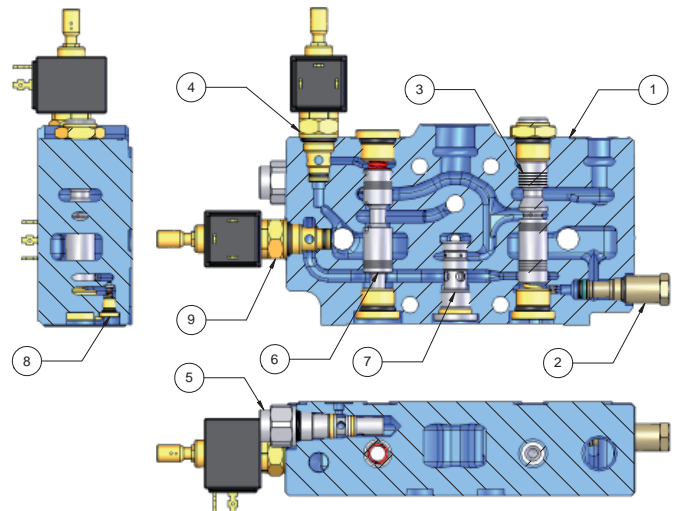

- 1. Inlet type DI01D
- 2. Main relief valve TB12
- 3. By-pass flow control spool unit..... FK402
- 4. Solenoid valve for el. high-low flow control E926
- 5. Pressure reducing valve.....TRA53
- 6. High/low flow control spool unit FV401
- 7. Metering orifice cartridge for low flow PF505
- 8. Cushioning check valve FSB4
- 9. Electrical unloading valve..... E926

Inlet section I21A - single flow range and manually operated

The I21A provides full RSQ 240 Q-function.

When equipped with an el. unloading valve (E926), emergency dump is achieved.

The integral TB12 in combination with flow control spool FK../TK.. form the primary relief valve function.

A number of by-pass flow control spools, with its integral metering orifice, are available to suit different system requirements in terms of pressure build-up, to achieve flow from the high pressure carry-over and to constitute max available service circuit flow by screwing home MF24 metering check valve.

I21A is equipped with a special check valve, FSB5, to cushion the opening of the by-pass control spool thereby eliminating unnecessary pressure peaks.

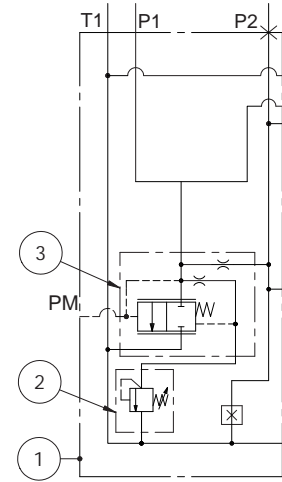

- 1. Inlet type A..... I21A
- 2. Main relief valve TB12
- 3. By pass flow control spool unit..... TK517
- 4. Plug..... PGT02

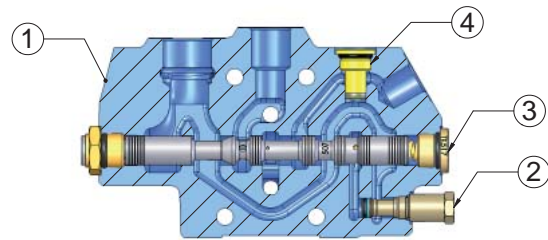

Inlet section I21B - single flow range and remote controlled

The properties of the I21B are the same as for I21A, with the addition that it can be equipped with a pressure reducing cartridge (TRA53) providing pilot oil supply for remote control.

- 1. Inlet type B I21B
- 2. Main relief valve TB12
- 3. By-pass flow control spool unit.....FK512
- 4. Pressure recucing valve.....TRA53
- 5. Cushioning check valve.....FSB5
- 6. Plug.....PGT02

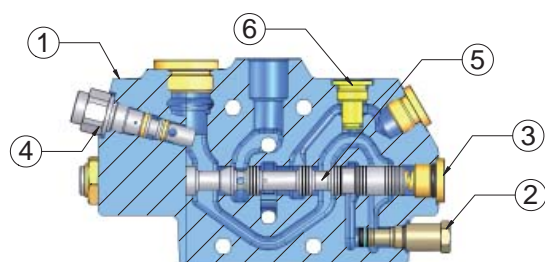
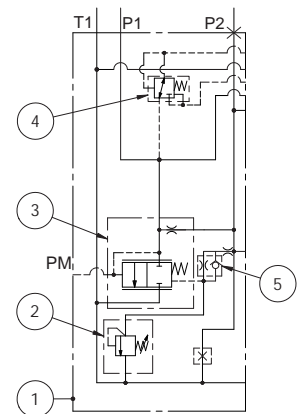



Working section S11B manually operated

With cavities for service port valves.

- 1. Working section..... S11B
- 2. Spool control bracket.....M01
- 3. Spool
- 4. Low flow check valveML24
- 5. Full flow metering check valve.....MF24
- 6. Spool control.....LE11
- 7. Port relief/anticavitation valve..... TBSD160
- 8. Port relief/anticavitation valve..... TBSD160

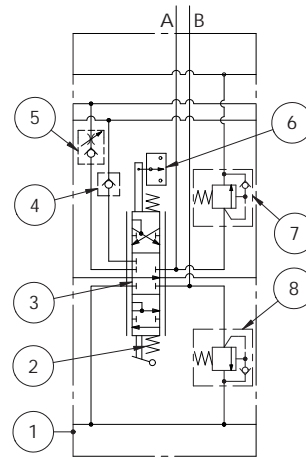
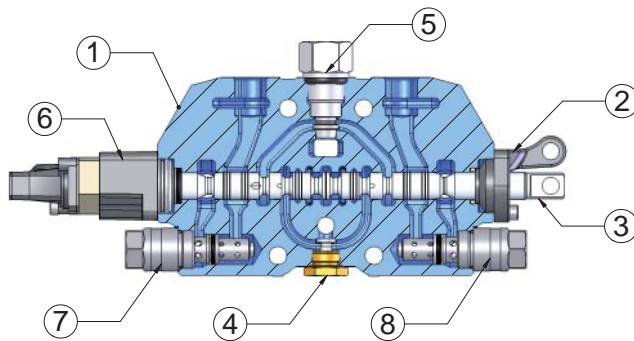

Working section S11C remote controlled

With cavities for service port valves and for solenoid operated valves for EHP.

- 1. Working sectionS11C
- 2. Solenoid valve EHP, 24 V.....ER54
- 3. Spool control.....MH02
- 4. Spool
- 5. Spool control..... HP04
- 6. Low flow check valveML24
- 7. Full flow metering check valveMF24
- 8. Solenoid valve EHP, 24 V.....ER54
- 9. Port relief valve..... TBD160
- 10. Port relief valve..... TBD160

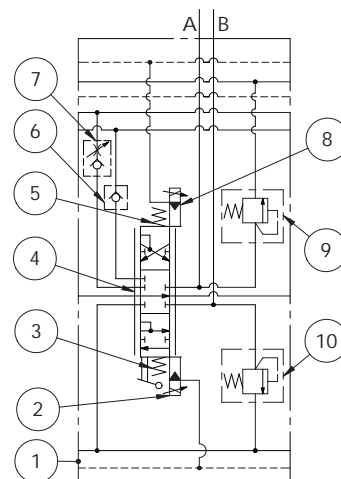
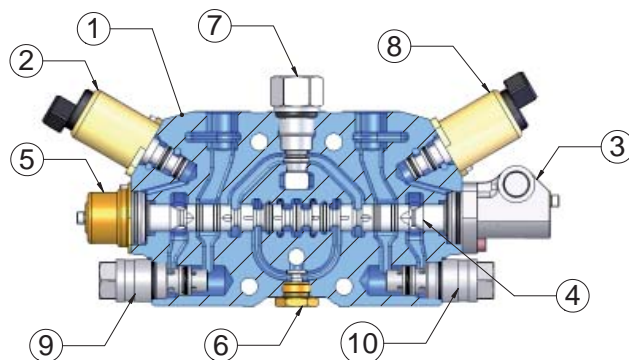

Outlet section U21A manually operated

With cavity for high pressure carry-over plug.

Note that the carry-over flow is the flow that is regulated into the centre channel i. e. the flow determined by the metering orifice of the inlet section.

- 1. Outlet section type A.....U21A
- 2. Plug.....P400

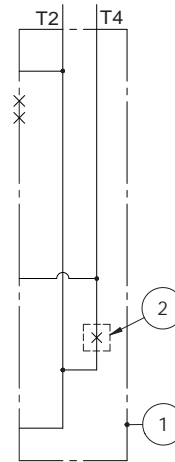
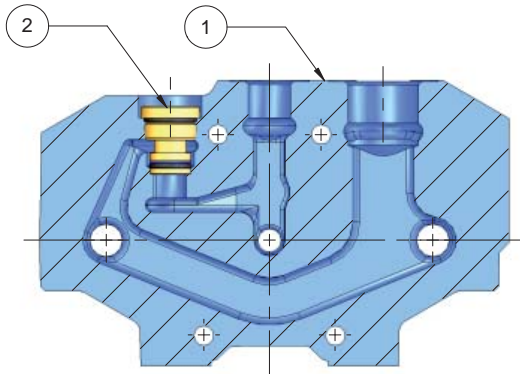

Outlet section U21B remote controlled

With cavity for high pressure carry-over plug.

With port (PPM) for external pilot oil supply/pilot pressure gauge.

With port (T3) for external pilot oil drain (provided plug PMS6 fitted in TD4).

With cross drillings for pilot oil supply to B-side of S11C sections.

- 1. Outlet section type B..... U21B
- 2. Pilot pressure valve TMB210
- 3. PlugPMS6

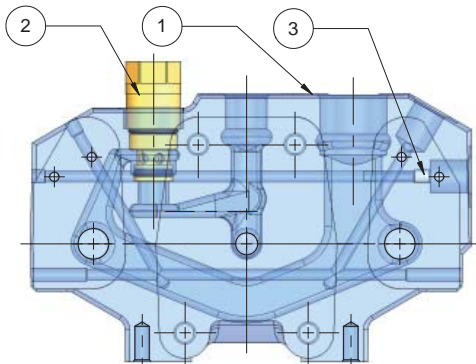

For optimal function it is recommended that port T3 is directly connected to tank and plug PMS6 fitted in TD4.

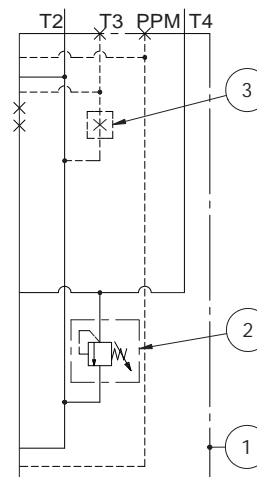



Outlet section U21C - Intermediate outlet

Intermediate outlet allowing dual circuit system. Intended both for manually and remote controlled valves.

With cavity for high pressure carry-over plug.

With port (PPM) for external pilot oil supply/pilot pressure gauge.

With port (T3) for external pilot oil drain (provided plug PMS6 fitted in TD4).

With cross drillings for pilot oil supply to B-side of S11C sections.

- 1. Outlet section type C.....U21C
- 2. Pilot pressure valveTMB210
- 3. Plug.....PMS6

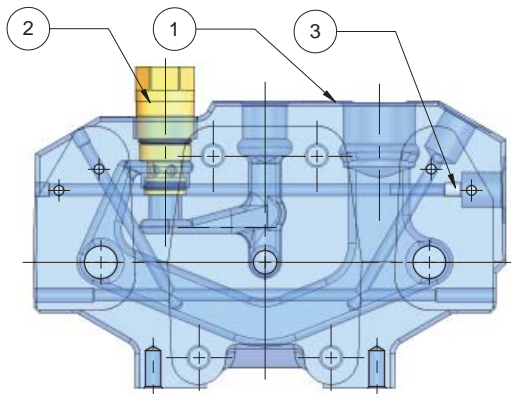
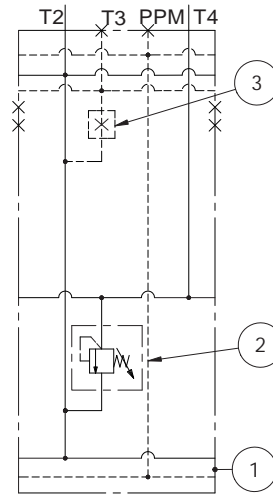

Electrical unloading valve and two speed control

This electrical unloading valve is a 2-way, normally open, solenoid type cartridge valve. It is an option in all inlet sections.

It is intended for emergency stop and for pressure drop/heat generation reduction.

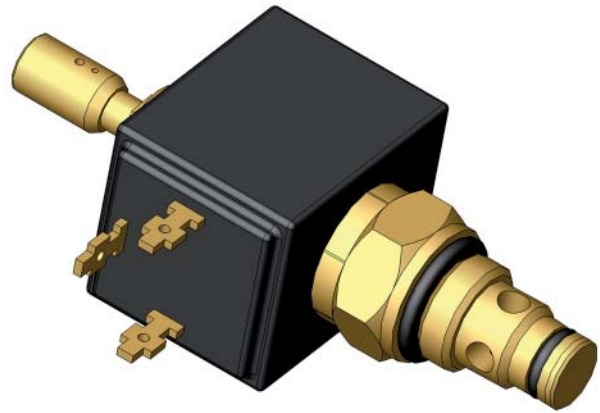

Data

Rated flow: 40 l/min
 Power consumption: 17 W
 Rated voltage: 12 and 26 V
 Max voltage variation: +/- 10%
 Duty factor*: 100%
 Connection: Hirschmann ISO 4400 DIN 43650
 Protection class: IP65
 * Sufficient cooling must be secured

The unloading valve has manual override.

E912 and E926 has push and twist type pin operation. This pin is sealable.

PE20 is the plug for the cavity.

The HG10 plug is used when the valve is hydraulically remote controlled by a hydraulic servo valve.

Codes

E912 push and twist type override 12 V
 E926 push and twist type override 26 V

E926 for two speed function, high/low flow

E926 for el. unloading/emergency stop

I11D

E926 for el. unloading/emergency stop

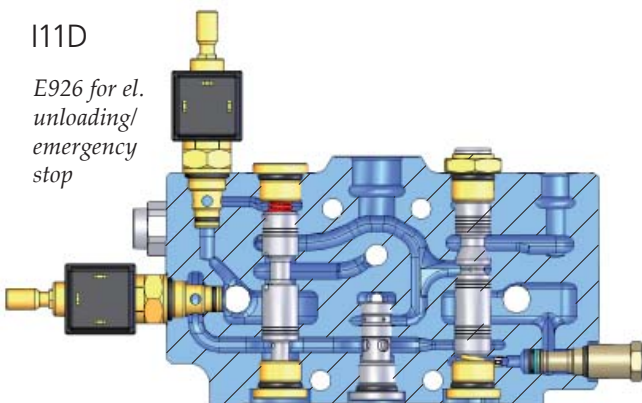

I21

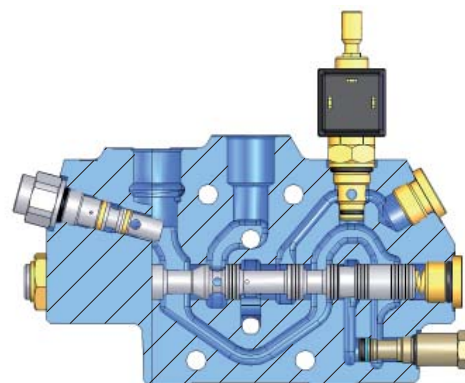



Spool controls - A-side

Spool control 901

Spring centered.

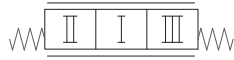

Spool control 1001

Detents at positions 1, 2 and 3.



Spool control 1101

Spring centering with detent at position 4.



Spool control HP

Hydr. proportional. For external pilot oil supply. Pilot pressure 6-16 bar Max pilot pressure 25 bar*.



Spool control L61

External hydraulic kick-out from inserted spool*.



Spool control L64

External hydraulic kick-out from inserted and extended spool, locking neutral position*.



Spool control LE11

Spool position indicator. Operating range 10-30 V. Output voltage, spool centered : < 1V. External electronics are required.



* Connection 1/4" BSP

Spool controls - B-side

Bracket M01

Bracket.

Bracket MH02

Bracket for manual override.

For valves in standard configuration spool controls are mounted on the A-side of the valve and the lever brackets on the B-side.

Hand lever ME180

The hand lever ME180 is designed to be used in combination with spool control MH02, but it is a separate item and must be ordered separately.

ME180 provides manual override for EHP controlled RSQ 240 valves.

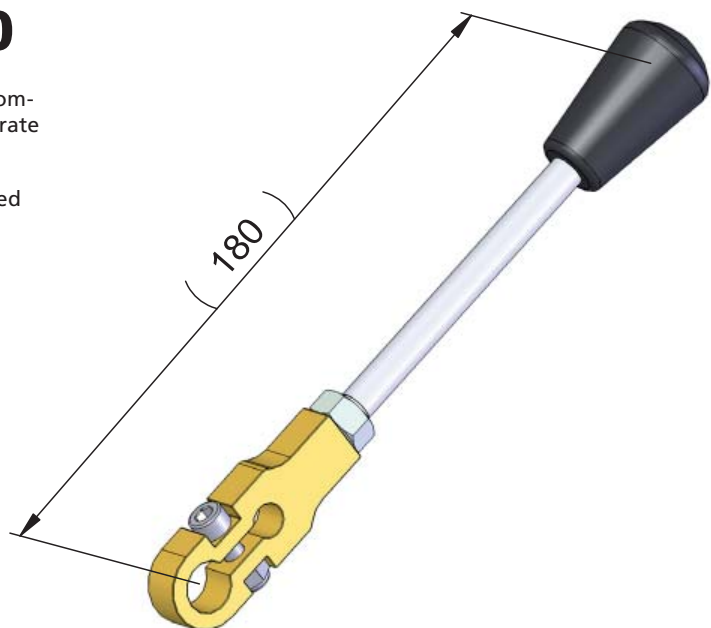

RSQ 240 Solenoid valve for EHP, ER52/54

ER52/54

ER52/54 are 3/2-way electrically operated pressure reducing valves used to provide controlled pilot pressure to operate valve spools.

Functional principle	PWM (Pulse Width Modulation)
Duty factor	100%
Connection.....	AMP Junior-Power-Timer
Recommended PWM frequency	100 Hz
Protection class.....	IP 65
Ambient temperature.....	- 30°C+ 80°C

Note: If used as "on-off" it is recommended to limit the current as example by using a coupling resistance. Please contact Nordhydraulic for detailed information.

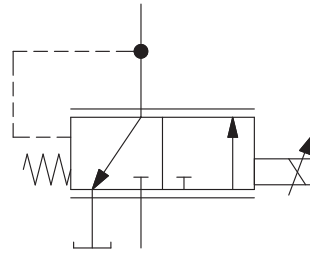

ER52

Rated voltage (+/- 2V)	12 V DC
Starting current	500 mA
Fully shifted	1200 mA
Coil resistance + 20°	5,4 Ohm

ER54

Rated voltage (+/- 4V)	24 V DC
Starting current	250 mA
Fully shifted	600 mA
Coil resistance + 20°	21,7 Ohm



Spools

The RSQ 240 spools are available in variety of flows and styles to accommodate most design requirements. Since the development of spools is a continuous process and all available spools are not described in this data sheet, contact Nordhydraulic for advice on choosing spools in order to optimize your valve configuration.

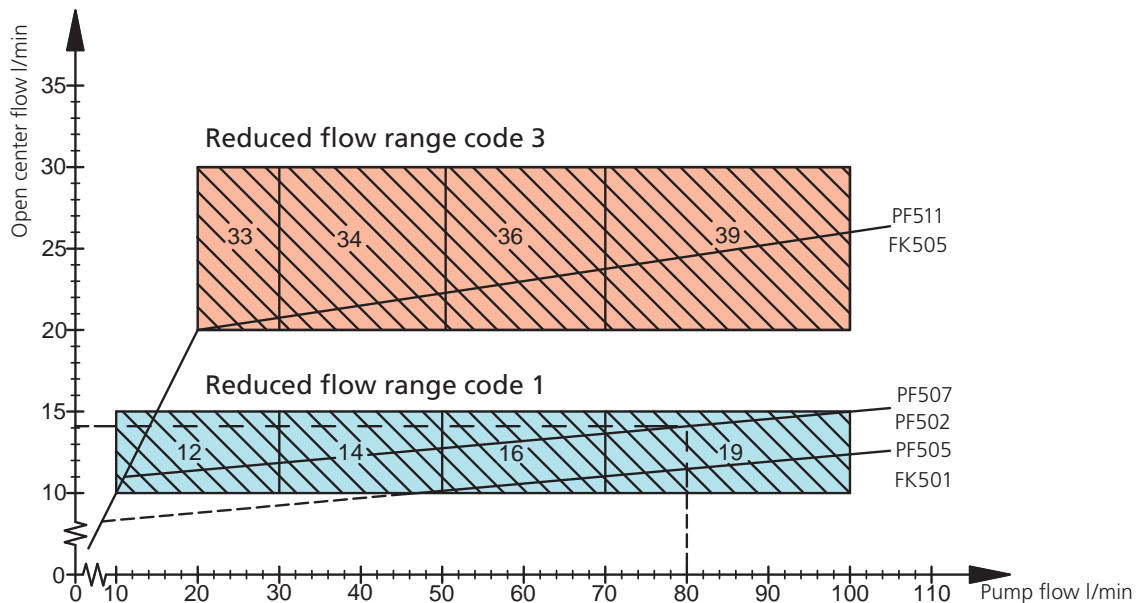

First digit in shaded squares represents reduced flow range code.
Second digit represents full flow range code.

PF5.. are metering orifices of I11D inlet.

FK5.. are flow control spool (with integral metering orifice) of I21.. inlets.)

How to choose metering orifice: If pump flow is 80 l/min, and wanted reduced speed flow is approx 15 l/min, then metering orifices PF507/FK502 will achieve an open centre flow of 14 l/min.

Principle spool matrix

	Flow range, l/min				
	Function/Type	10-30	30-50	50-70	70-100
	Double acting spool / 1	112	114	116	119
	Single acting spool/ 2	212	214	216	219
	Motor spool / 4	412	414	416	419
	Double acting spool with 4th pos. for float / 3	312	314	316	319

Spools in reduced flow code 3 (upper shaded area above) are also available. Spools specially developed for truck cranes (also for use in systems with load holding valves), as well as other application adapted spools are available. Contact Nordhydraulic! Recommended low flow range: 10- 30 l/min.

Main relief valve

Main relief valve TB12

The bypass flow control valve FK.. in combination with the relief valve cartridge TB12 form the pilot operated relief valve function of the inlet sections for the primary circuit.

TB12 is adjustable and sealable.

Setting range: 35 - 350 bar (3,5 - 35 MPa).
Setting range step: 5 bar.

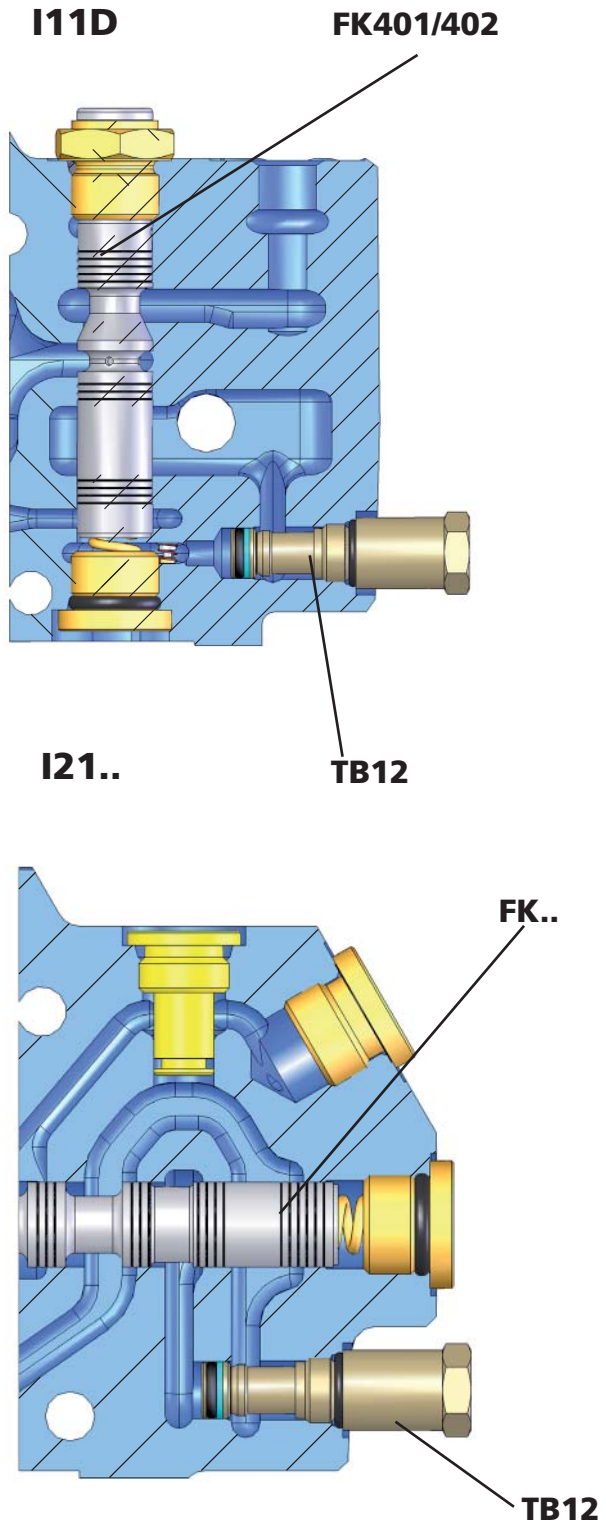
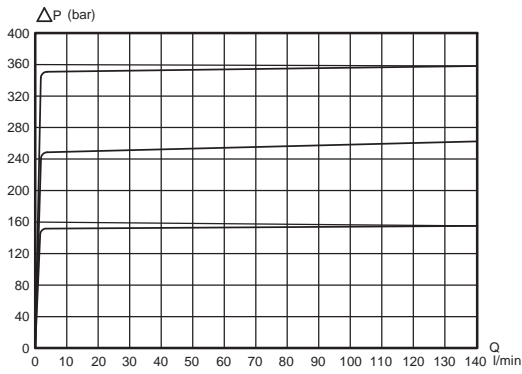
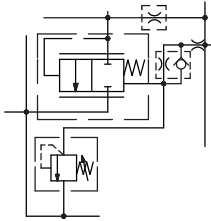



Service port valves

RSQ 240

Port relief valve TBD160

The TBD160 is a differential area, direct acting relief valve, for the secondary circuit.

TBD160 is adjustable and sealable.

Setting ranges for TBD and TBSD160:
 Setting range: 35 - 350 bar (3,5 - 35,0 MPa).
 Setting range step: 5 bar.

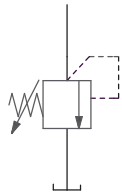
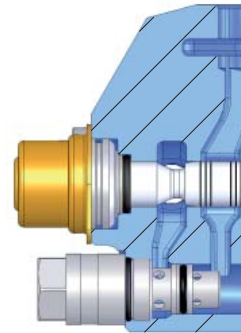

Port relief and anticavitation valve TBSD160

See TBD160 for functional principle.
 TBSD160 is adjustable and sealable.

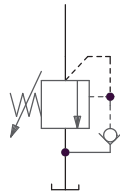
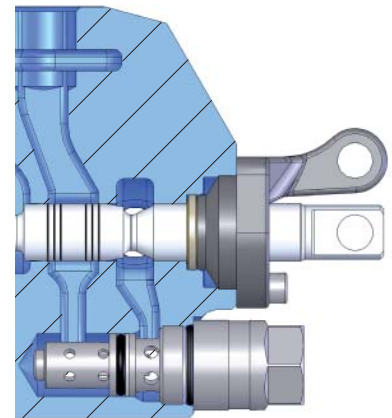

Relief characteristics TBD/TBSD160

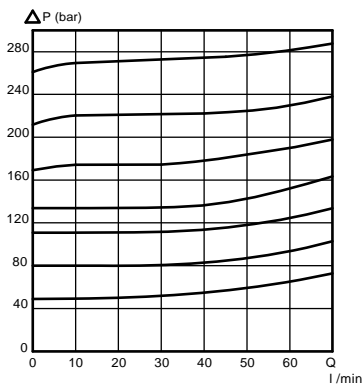

Anticavitation characteristics TBSD160

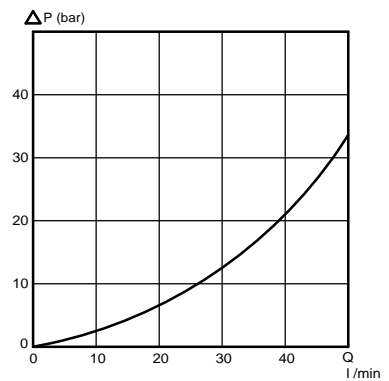

Service port valves

Port relief and anticavitation valve TBS400

Combination of pilot operated relief and anticavitation valve.

TBS400 is adjustable and sealable.

Setting range: 35 - 350 bar (3,5 - 35,0 MPa).
Setting range step: 5 bar.

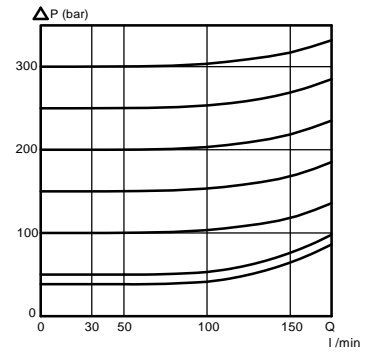
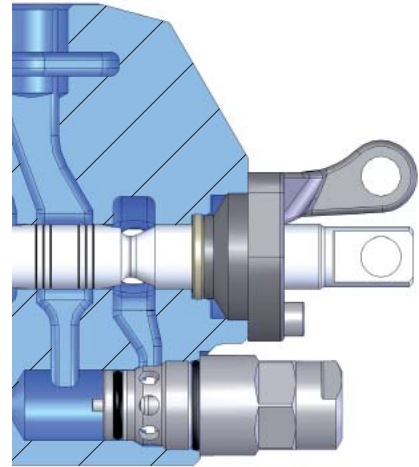
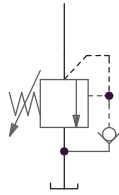

Anticavitation valve SB500

The anticavitation valve service to ensure that, in the event of a lower pressure in the cylinder port than in the tank, oil can be drawn from the system oil tank to the consumer.

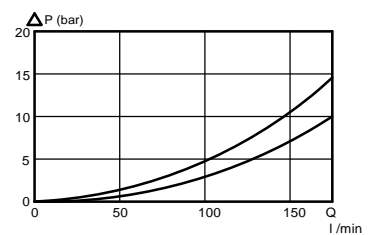
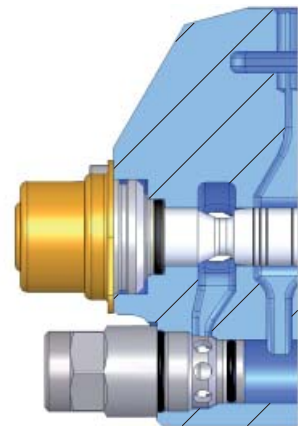



Miscellaneous

RSQ 240

Pressure reducing valve TRA53

The cartridge type pressure reducing valve TRA53 is used in inlet section I11D and I21B to provide pilot oil supply for remote control.

TRA53 is fixed set at 24 bar which consequently is the maximum available pressure level in the pilot system.

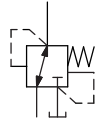
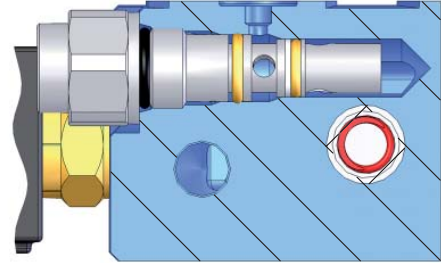

Pilot pressure valve TMB210

The cartridge type pilot pressure relief valve TMB210, normally set at min 14 bar, is used in outlet section U21B and U21C to secure available pilot pressure build-up for remote control. Depending on system design this necessary starting pressure could also be achieved through downstream arrangements, for example a support leg valve.

TMB210 is adjustable and sealable.

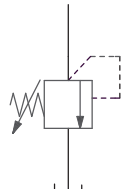
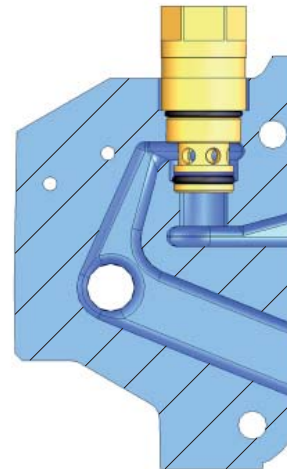

Typical hydraulic circuit diagrams

- For dual flow range
- Single circuit
- El. hydr. prop. remote control

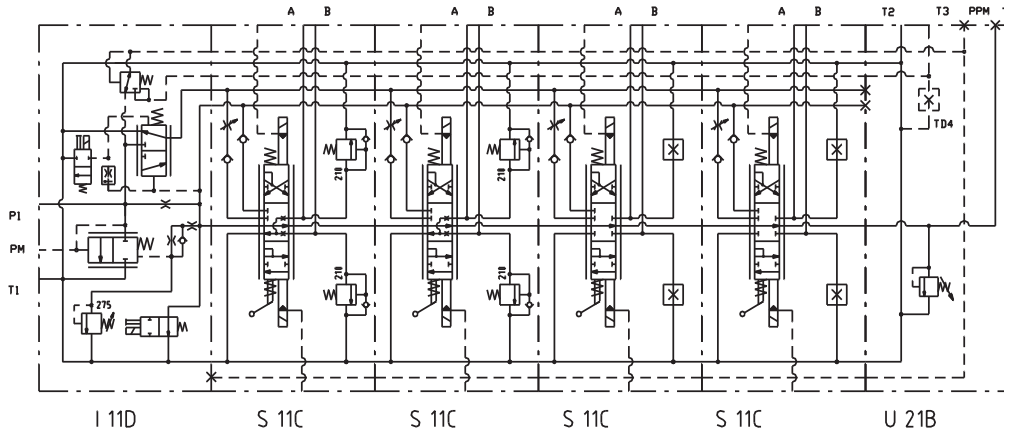

- For single flow range
- Single circuit
- Manually operated

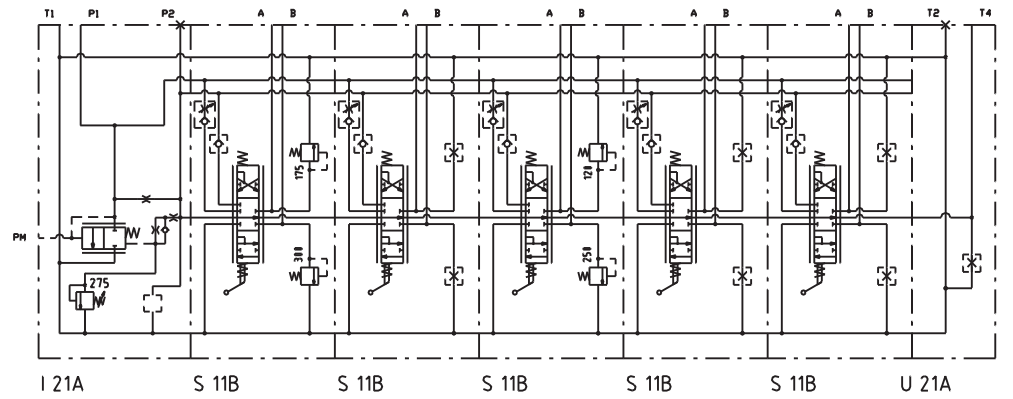

- For single flow range
- Dual circuit
- Manually operated

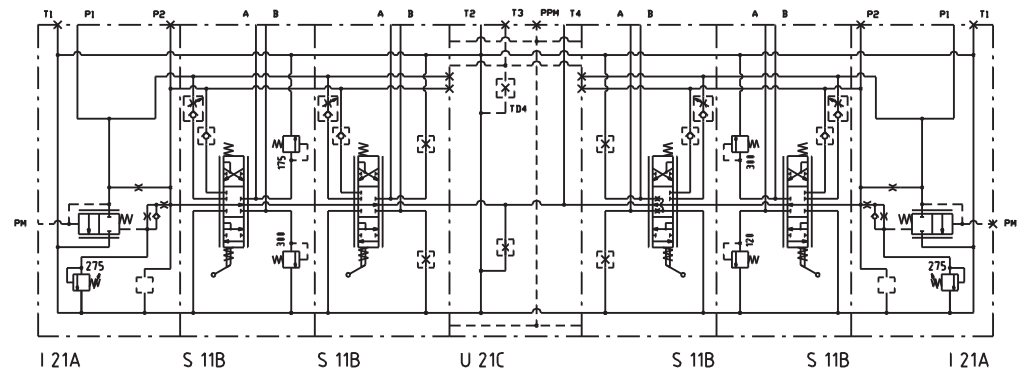

- For single flow range
- For systems with variable pump
- El. hydr. prop. remote control

