

HYDAC INTERNATIONAL

HYDAC Process Technology Water Filtration Product Overview

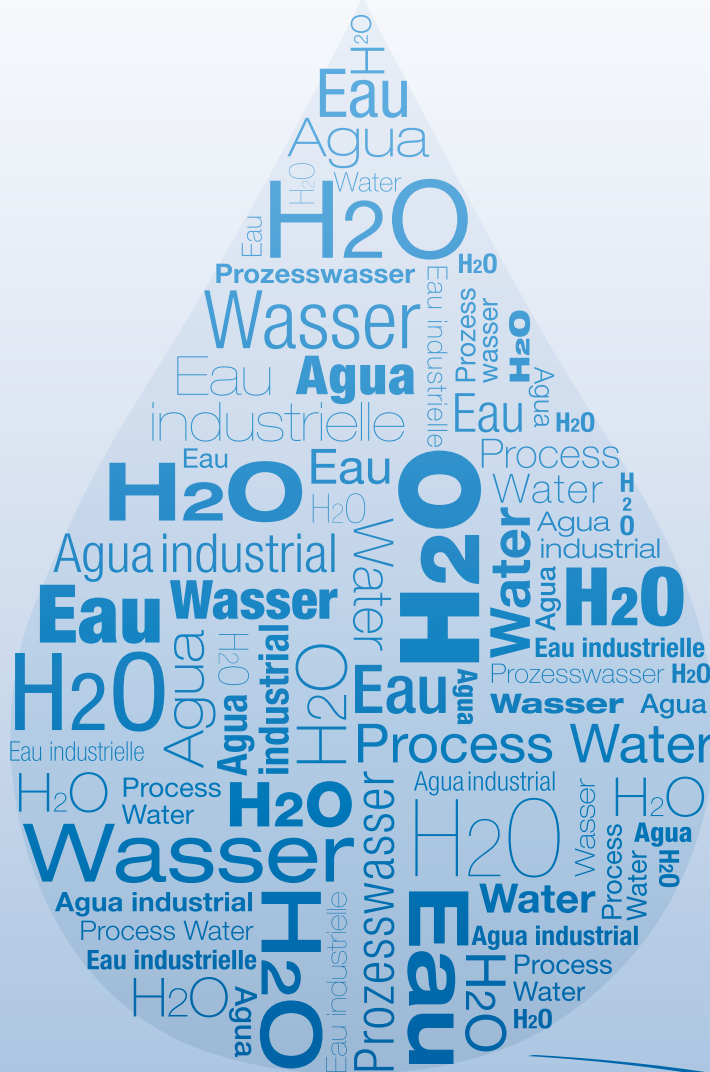

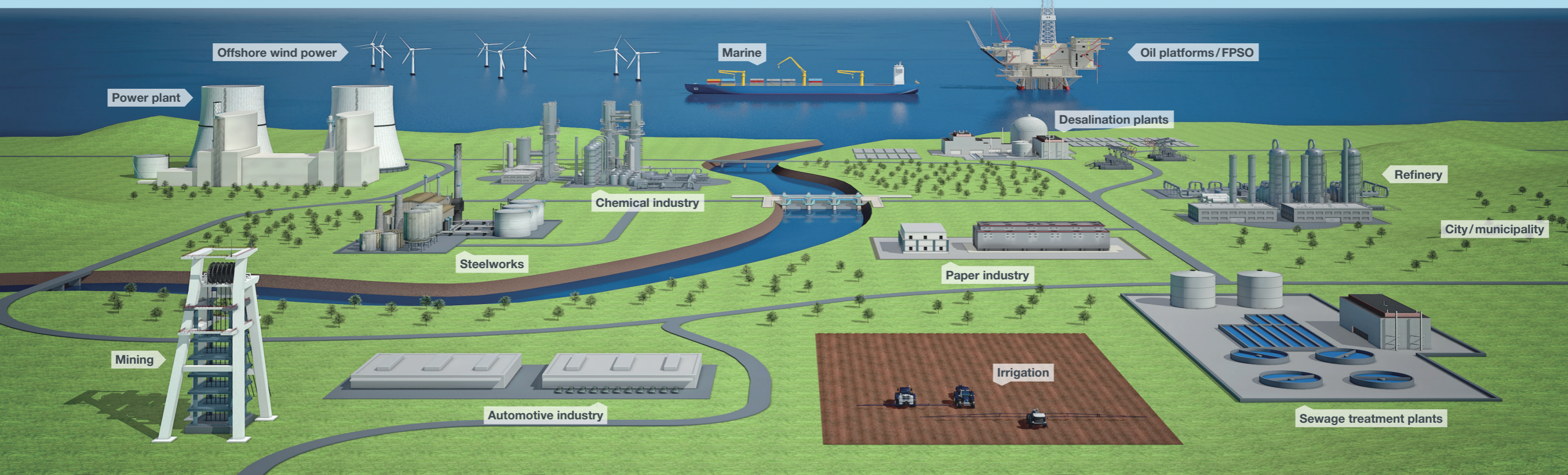

Every drop counts...

Our "blue planet" will only carry its name as long as its life sustaining water resources do not dry up.

The use of modern filter technologies allows for the more efficient use and reprocessing of water resources and thus contributes sustainably to the conservation of the earth's water resources.

Certified environmental management

DIN EN ISO 9001
DIN EN ISO 14001

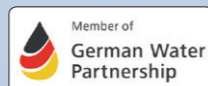

Filtration seen as a sustainable resource



HYDAC process filters for the efficient filtration of...

- Process water
- Membrane feed water
- Scrubber water
- Cooling water
- Service water
- Sealing water
- Injection water
- Ballast water
- Water spray
- and many more

The earth's water resources

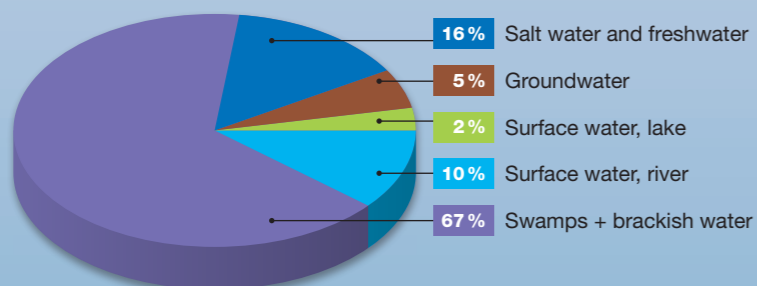

Reduce Operating Costs with HYDAC Filter Solutions

Membrane filtration

- In the area of water treatment, various pressure-driven membrane processes are employed:
 - Micro filtration
 - Ultra filtration
 - Nano-filtration
 - Reverse osmosis
- In so doing, the smallest particles (retentate) are retained and removed by a membrane.

“Poor pre- filtration can cause damage and prove expensive...”

Challenge

- Particulate contaminants can cause damage to membrane filters:
- Damaged membranes increase the risk of contamination reaching the clean water side
- Results in expensive maintenance and repair work as well as downtimes
- When using conventional automatic filters a relatively large pre-filter pump system is required

Automatic pre-filtration – AutoFilt® RF10 with innovative filter technology reduces the costs of pump system pre-filters

Conventional back-flushing filter

Required operating pressure min. 2 bar, back-flushing pressure min. 1.5 bar

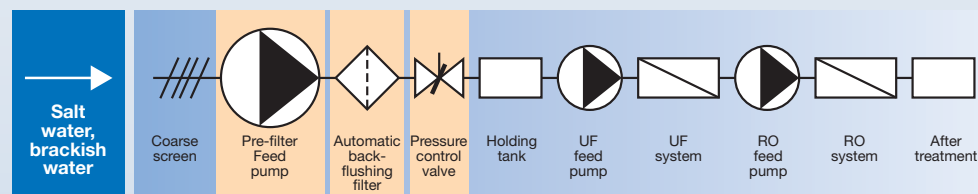

Cost driver:

- Pre-filter pump installations must have large enough dimensions
- Additional control devices for setting the required filtrate pressure of 1.5 bar

→ HYDAC solution: HYDAC AutoFilt® RF10

Highly efficient back-flushing under low pressure conditions and with long back-flushing line

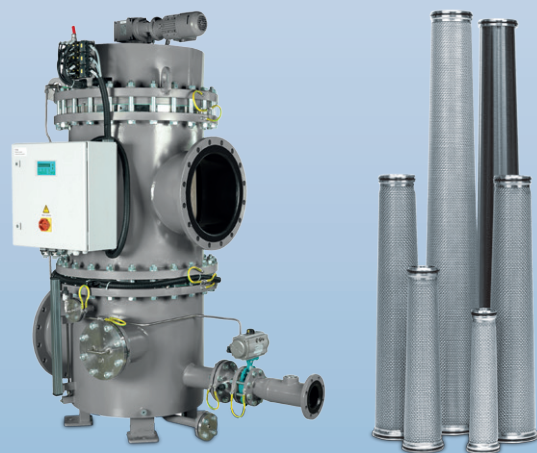
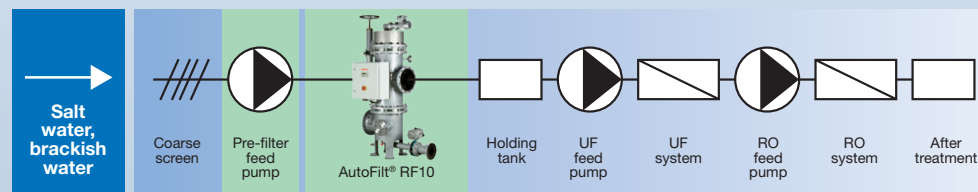

Finest filtration – the process line filters PLF1 and PLF2 ensure a reduced differential pressure and longer service life

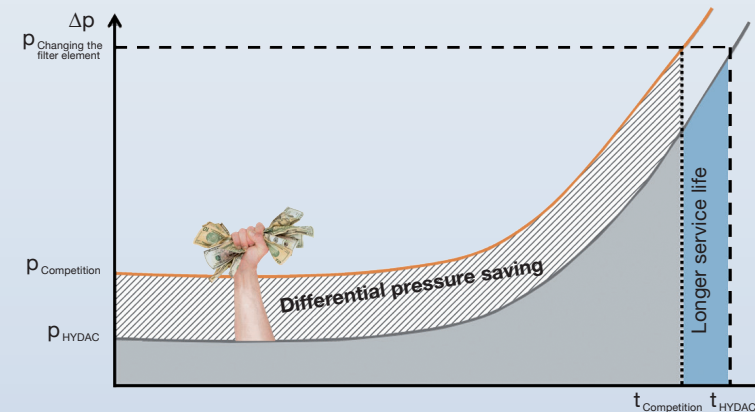

Longer service life
Thanks to our high-quality filter elements you benefit from optimal filtration and a longer filter element service life.



Save energy costs

With our filter elements, you can benefit from a very low differential pressure. Even a differential pressure saving of 0.49 bar can produce energy savings of up to €42k, depending on the flow rate.



HYDAC Water Filtration – Work Areas and Fineness

Challenges in water treatment...

A reverse osmosis plant based on semi-permeable membranes is usually at the end of the water processing chain. The pre-filtered untreated water is pumped back through the membrane with a high pressure pump in order to separate it into pure water and waste water.

It becomes clear why the condition of the untreated water is of particular importance for the **reverse osmosis (RO)**: contaminated or damaged membranes result in pressure losses and eventually in downtimes or damages to the entire system.

...and the solution from HYDAC

Filter solutions from HYDAC can be used both as **protective filters** and **work filters**. As protective filters they would be used for the pre-treatment of the media for the protection of **ultra filtration systems (UF)** or **multi-media filters (MMF)**, and as work filter they can even take over the functions of ultra-filtration systems (UF) or multi-media filters (MMF) and perform the entire pre-treatment of the water prior to the reverse osmosis.

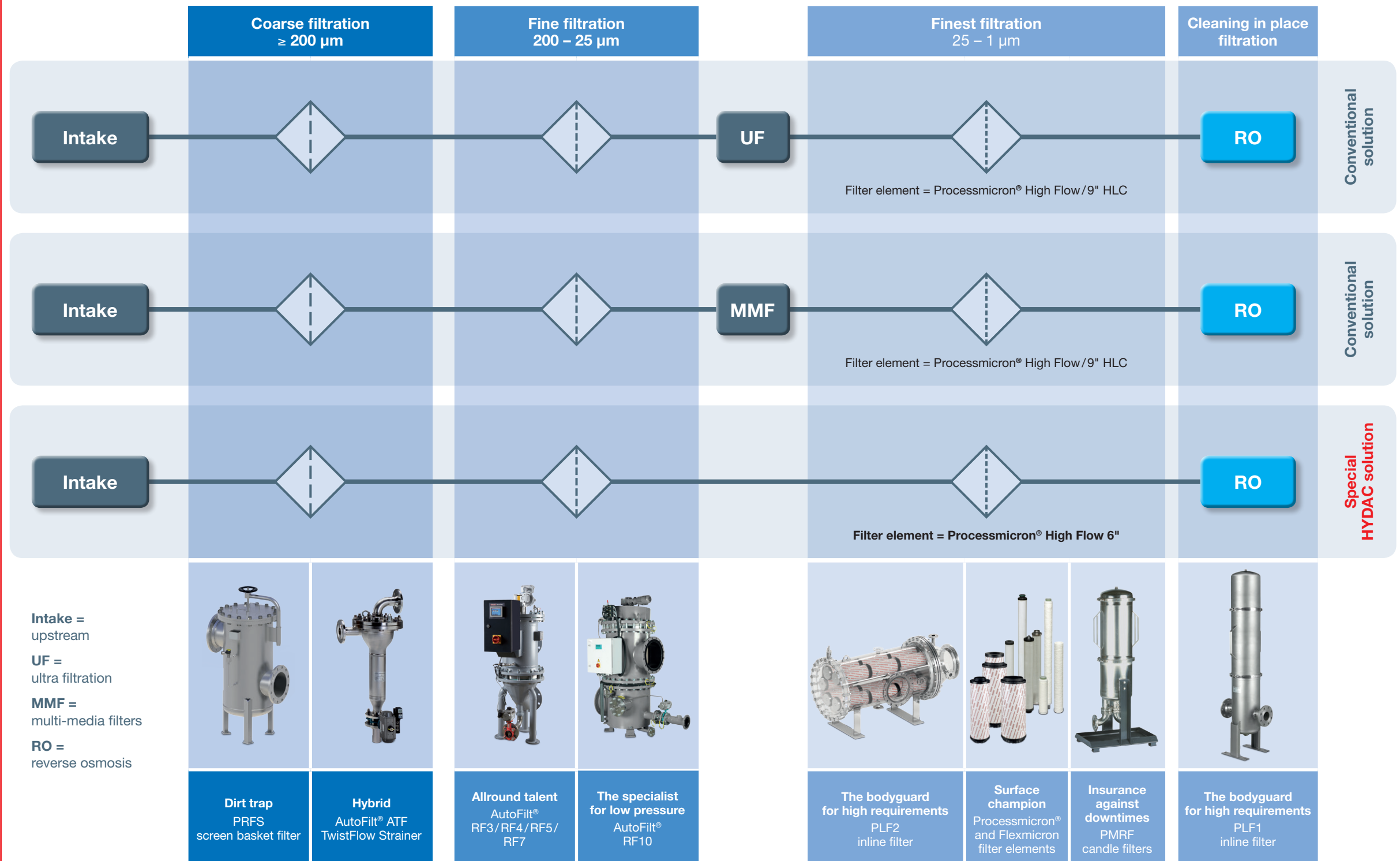

Intake = upstream
 UF = ultra filtration
 MMF = multi-media filters
 RO = reverse osmosis

The Dirt Trapper: Process Screen Basket Filter PRFS/PRFSD

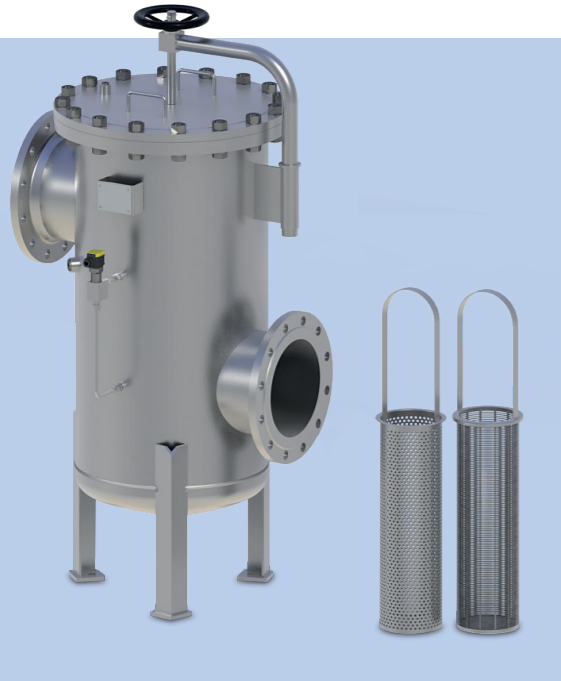

Product description

- Screen basket filter – also available as double filter
- Used as coarse filter, bypass filter or pre-separator

Screen basket technology

- Screen basket insert with bracket
- Wire mesh 25 to 1000 µm
- Wedge wire: 50 to 3000 µm
- Perforated plate 3000 to 10000 µm

Product advantages

- High filtration efficiency
- Simple handling
- Robust filter materials – ideal for long-term operation
- Cleanable filter materials
- Low operating costs
- Particles cannot enter the clean side when changing the basket
- Also available as a switchable double filter

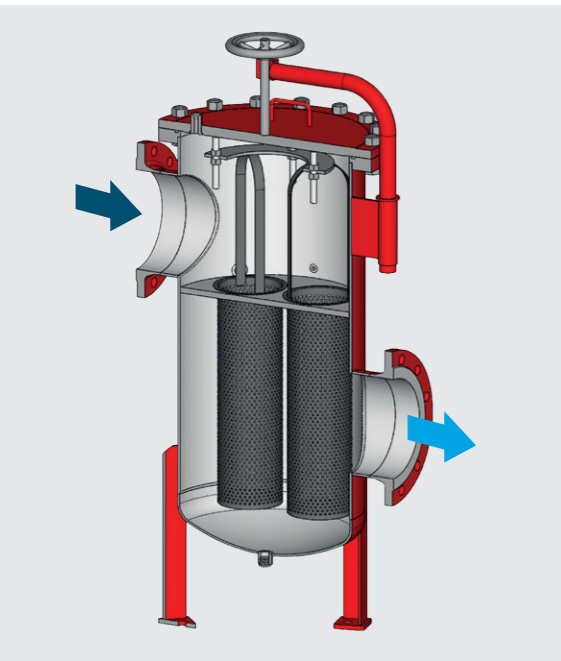

Sectional view PRFS

Specifications	PRFS/PRFSD screen basket filter
Nominal size	● DN 50 – DN 700
Volume flow Q_{max}	● 3600 m ³ /h
Operating pressure p_{max}	● 16 bar
Filtration ratings	● 25 µm to 10000 µm

The Hybrid: Automatic Filter AutoFilt® ATF TwistFlow Strainer



Product description

- Coarse separation by centrifugal force with guaranteed filtration ratings
- 2-stage operating principle:
 1. Centrifugal separation tackles → High contamination loads
 2. Conical filter element → Guarantees the filtration rating

Filter element technology

- Depending on the specific weight, even particles < 100 µm are separated effectively
- Wedge wire or SuperMesh wire mesh 200 to 3000 µm
- Optional: SuperFlush non-stick coating

Product advantages

- No transfer of contamination to the clean side
- Suitable for a wide variability in the quality of untreated water
- Consistent filtrate quality
- Also available as skid solution for high flow rates

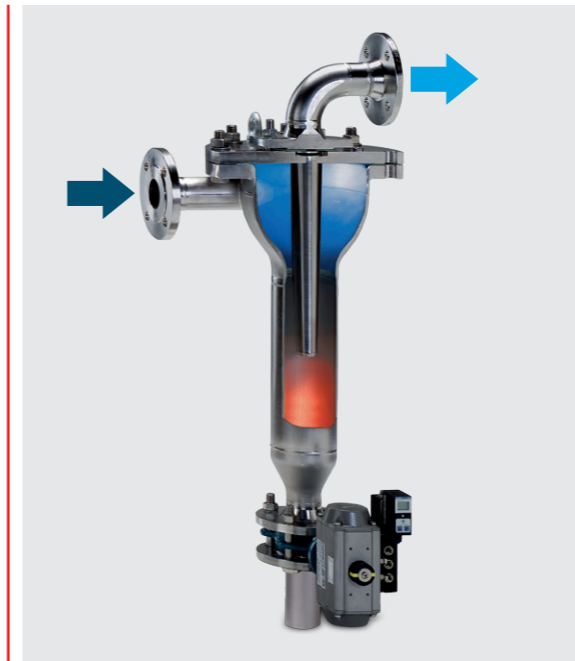

Sectional drawing for AutoFilt® ATF



Skid solution

Specifications	AutoFilt® TwistFlow Strainer ATF
Nominal size	● G 1" – DN 200
Volume flow Q_{max}	● 400 m ³ /h, higher volume flows with skid solution possible
Operating pressure p_{max}	● 16 bar
Filtration ratings	● Dependent on particle nature and operating conditions

Mode of operation

Filtration

- Fluid enters the housing tangentially
- As a result of the tangential inflow and the conical housing cross-section, the fluid flows down in a spiral shape
- Particles with a high density are pressed against the housing wall by the centrifugal forces, and are deposited in the lower section of the housing
- Particles with a low density, which are not deposited below, are separated out by the conical slotted tube filter element with a defined filtration rating

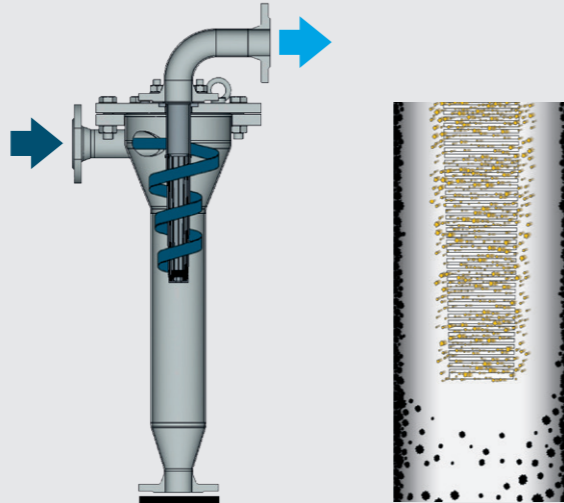

Cleaning

- Deposited particles and those separated by the conical slotted tube filter element collect in the lower section and are removed periodically
- Cleaning is performed by flushing with unfiltered fluid
- Filtration is continuous as only partial flow is used for flushing

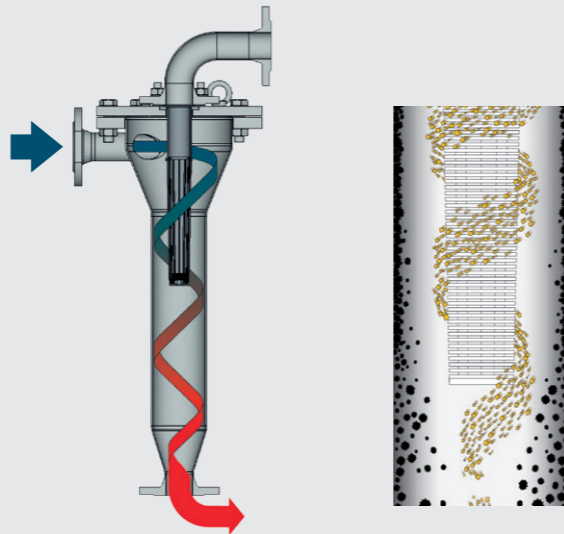

The AutoFilt® TwistFlow Strainer ATF can achieve ratings finer than 200 µm

Depending on the specific weight, even particles < 100 µm are separated effectively. Whereas with conventional hydrocyclones under changed operating conditions there is the risk of contamination reaching the clean side, the conical wedge wire in the AutoFilt® ATF performs a protective function (safety filter) with defined filtration ratings and thus prevents contamination reaching the clean side.

Efficiency / particle size	Specific weight 7.5 g/cm ³	Specific weight 2.6 g/cm ³	Specific weight 1.7 g/cm ³
> 100 µm	99 %	98 %	77 %
100 – 75 µm	92 %	84 %	35 %
75 – 50 µm	87 %	78 %	21 %

The Allrounder: Automatic Filters AutoFilt® RF3 / RF4 / RF5 / RF7



Product description

- Self-cleaning automatic filter in
 - **vertical design:** AutoFilt® RF3 / RF4 / RF5
 - **horizontal design,** space-saving: AutoFilt® RF7
 - **compact design** for low volume flows: AutoFilt® RF4
 - **economy design** with vertical inlet, up to 200 µm: AutoFilt® RF5

Filter element technology

- Conical filter elements
- Wedge wire: 50 to 3000 µm
- SuperMesh wire mesh: 25 to 60 µm

Product advantages

- Automatic back-flushing reduces operating costs
- Isokinetic filtration and back-flushing provides greater efficiency
- Variable flange positions
- Numerous material and control variants
- No interruption of the filtrate flow during back-flushing
- Proved its worth over a thousand times

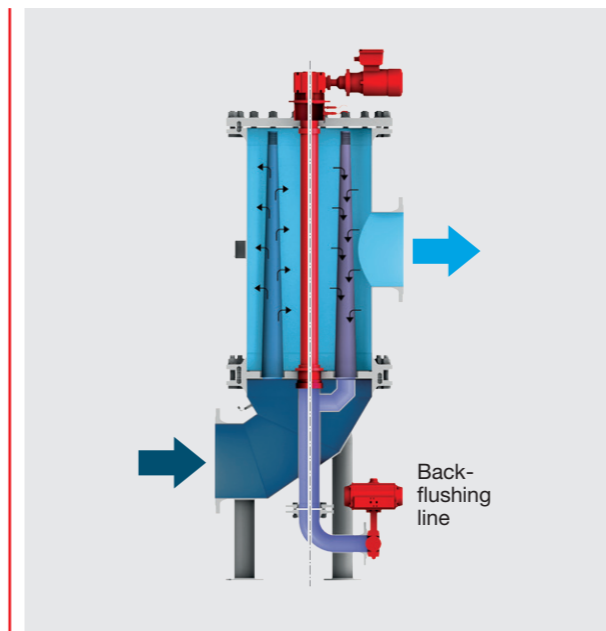

Sectional drawing for AutoFilt® RF3

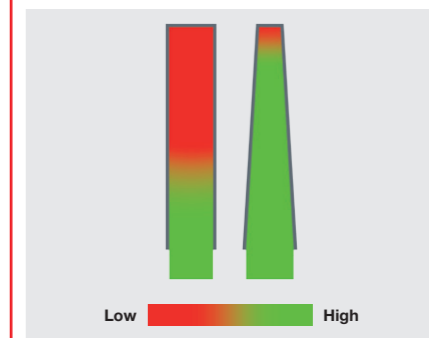

Back-flushing efficiency in conical filter elements compared to conventional cylinder filter elements

Specifications

Nominal size
Volume flow Q_{max}
Operating pressure p_{max}
Filtration ratings

AutoFilt® RF3 / RF4 / RF5 / RF7

- G 1" – DN 900
- 7500 m³/h
- 100 bar
- 25 µm to 3000 µm

The Specialist for Low Pressure – Automatic Filter AutoFilt® RF10

Versions

AutoFilt® RF3

The allrounder – proved its worth over a thousand times

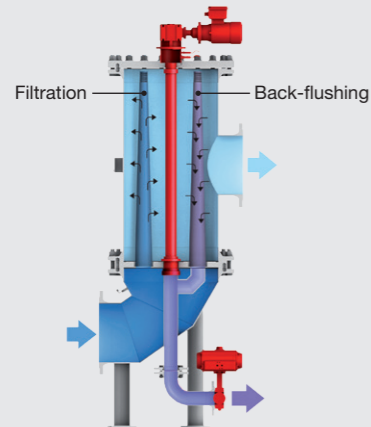

AutoFilt® RF4

Compact for low flow rates

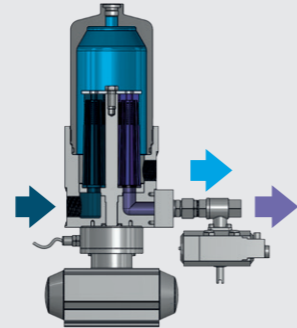

AutoFilt® RF5

Economy with vertical inlet up to 200 µm

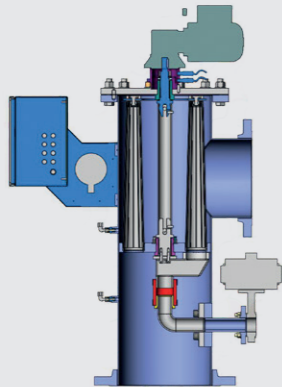

AutoFilt® RF7

Horizontal design saves space

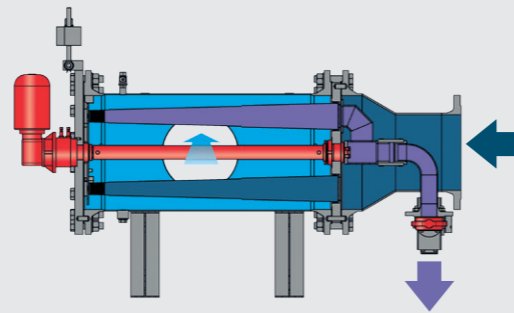

Mode of operation

Filtration

- The medium being filtered flows through the filter elements from the inside to the outside
- Contamination particles then collect on the smooth inside of the filter elements
- As the level of contamination increases, the differential pressure between the contaminated and clean sides of the filter increases. If the pressure loss reaches the differential pressure trigger point, back-flushing starts automatically

Back-flushing

- AutoFilt® RF3/RF5/RF7: The gear motor rotates the flushing arm under the filter elements that need cleaning
- AutoFilt® RF4: During automatic back-flushing, the pneumatic drive rotates the filter element plate, including the filter elements, into the correct position, so that a contaminated filter element sits over the flushing opening
- The back-flush valve is opened
- The pressure drop between filtrate side and back-flush line flushes a small amount of the filtrate back through the contaminated filter elements
- The contaminant particles deposited on the inside of the filter elements are loosened and flushed into the back-flush line via the flushing arm

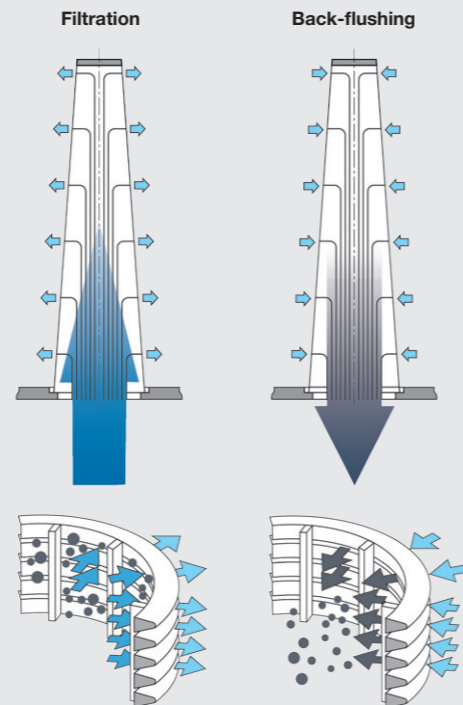

Product description

- Self-cleaning automatic filter
- Hydrodynamic suction effect
- Conical JetFlush technology

Filter element technology

- Conical filter elements
- Wedge wire: 50 to 3000 µm
- SuperMesh wire mesh: 25 to 60 µm

Product advantages

- Back-flushing independent of pressure on clean side of filter
- Dependent only on the inlet pressure
- Highly efficient back-flushing with low pressure conditions and long back-flush lines
- Suitable for high contamination loads and contamination peaks

Inlet back-flushing line

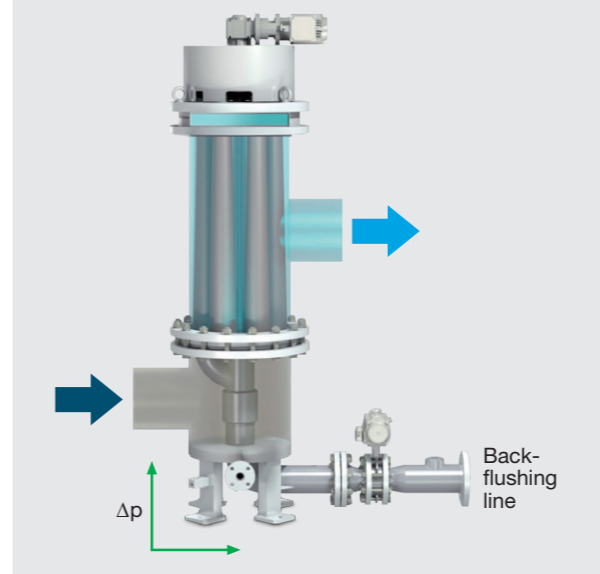

Back-flushing independent of pressure on clean side of filter

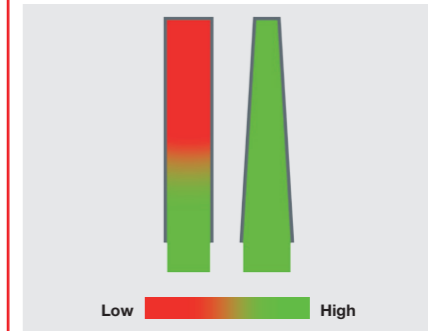

Back-flushing efficiency in conical filter elements compared to conventional cylinder filter elements

Specifications

Nominal size	• DN 100 – DN 600
Volume flow Q_{max}	• 3500 m ³ /h
Operating pressure p_{max}	• 6 bar
Filtration ratings	• 25 µm to 3000 µm

AutoFilt® RF10

Nominal size	• DN 100 – DN 600
Volume flow Q_{max}	• 3500 m ³ /h
Operating pressure p_{max}	• 6 bar
Filtration ratings	• 25 µm to 3000 µm

Filtration function

Filtration

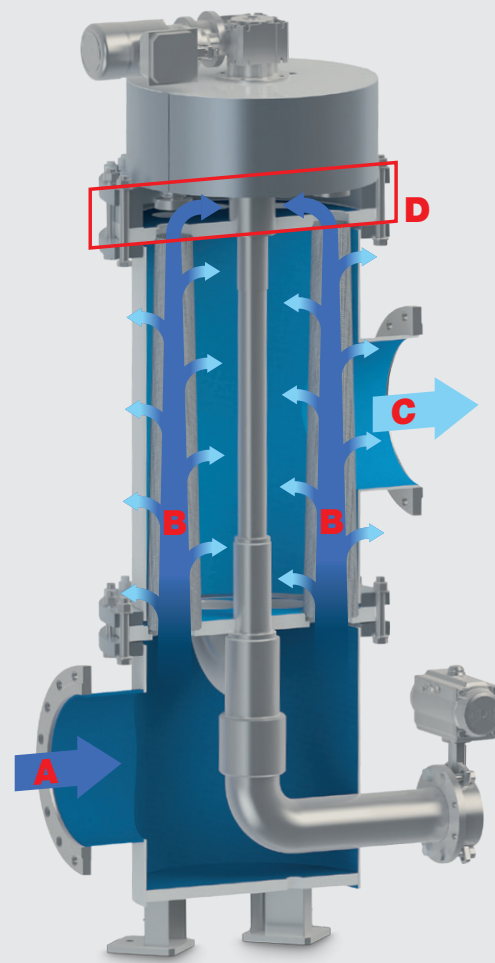

Filtration without interrupting production: Consistent performance and cleanliness

- The medium being filtered enters the filter housing via the filter inlet **A** and flows through the filter elements of the back-flushing filter from the inside to the outside **B** and leaves the filter via the filter outlet **C**
- During the filtration process, the JetFlush reservoir **D** located above the filter elements is filled with medium from the dirty side
- As fluid is filtered, particles collect on the inside of the filter elements
- As the level of contamination increases, the differential pressure between the contaminated and clean side of the filter increases
- When the differential pressure reaches the pre-set trigger point, back-flushing starts automatically

Triggering back-flushing

Automatic back-flushing is triggered:

- In case of exceedance, the differential pressure is triggered
- By means of a timer
- By pressing the test button

Back-flushing function

Back-flushing – Phase 1

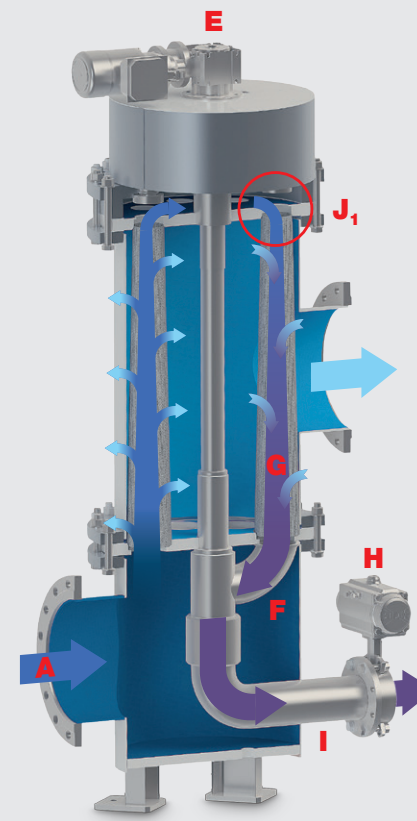

Back-flushing – Phase 2

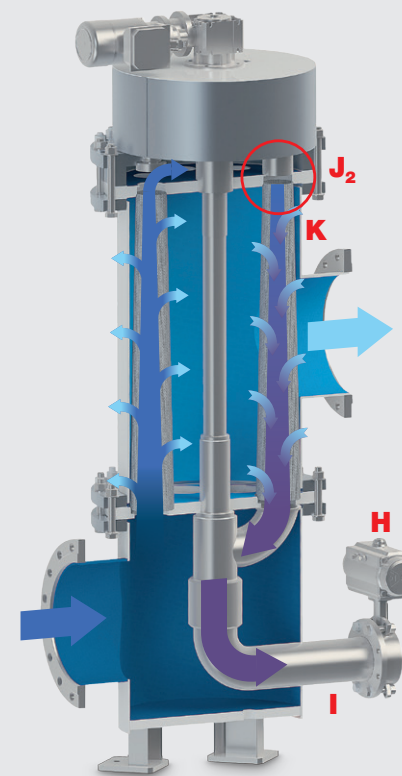

Simultaneously during filtration

Phase 1 of back-flushing – Removing the contamination particles

Back-flushing in general:

- The gear motor **E** rotates the flushing arm **F** to the filter element to be cleaned **G**
- The back-flush valve **H** opens
- The pressure drop between the filter inlet **A** and the back-flush line **I**, combined with the conical geometry of the element triggers the special jet-flush effect of the AutoFilt® RF10
- The remaining filter elements continue filtering to ensure uninterrupted filtration

Phase 1 of back-flushing – Stripping away the contamination:

- In the first phase, unfiltered fluid from the JetFlush reservoir **J1** above flows into the filter element
- The conical filter element geometry produces a core flow here, supplied mainly by the JetFlush reservoir
- This core flow is supported by the open JetFlush effect which also draws water from the filtrate side into the inside of the filter element

Effective back-flushing without interrupting filtration

Phase 2 of back-flushing – Discharging the contamination:

- Once the core flow has developed, the JetFlush reservoir located above the filter element is closed **J2**
- Closing the filter element initiates the second phase, namely discharging the contamination: The fluid column which is already moving sucks water from the filtrate side to **K** because no fluid is entering the filter element because it is now closed at the top
- Due to the conical filter element geometry, the whole surface of the filter element is now clean and residue-free
- The contamination is discharged via the back-flushing line **I**
- After cleaning the filter element, the flushing arm rotates to the next filter element to be cleaned; the process is repeated
- When the back-flush cycle is finished, the back-flush valve is closed **H**

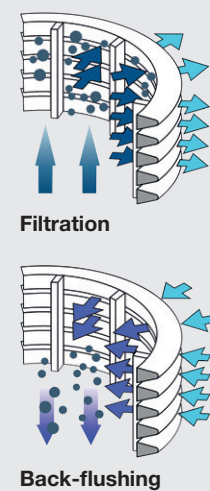
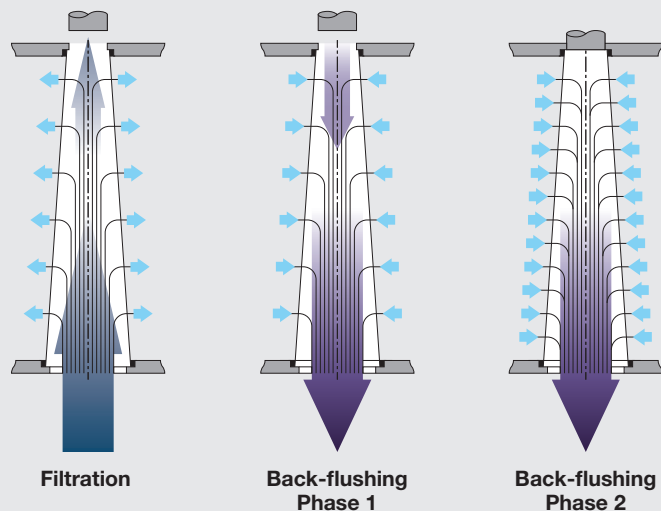

Bodyguard for High Requirements – Inline Filter PLF1 up to 200 m³/h



Product description

- Continuous separation of solids from low viscosity fluids
- One-step filter housing for up to two filter elements
- Flow rates up to 200 m³/h

Filter element technology

- High quality filter elements made from polyester or polypropylene
- Multi-layer filter mat construction
- Staged (graduated) depth filtration
- Protection for the clean side

Processmicron® filter elements in 3 versions:



- 1) Work filtration:**
Larger flow surface for higher contamination loads
→ HighFlow 6"



- 2) Comprehensive work filtration:**
Double the safety, even for contamination peaks due cascade effects
→ HighLoadCascade 9"



- 3) Protective filtration:**
High volumetric flows
→ HighFlow 9"

Product advantages

- Excellent deposition rates
- Low pressure drops due to large cross sections and filter areas
- Very large filter area per filter element
- Compact design with high flow rates
- Flow-optimised design
- Protection of the clean side during element change
- High contamination retention capacity
- Modular design gives optimal flexibility in catering for every application

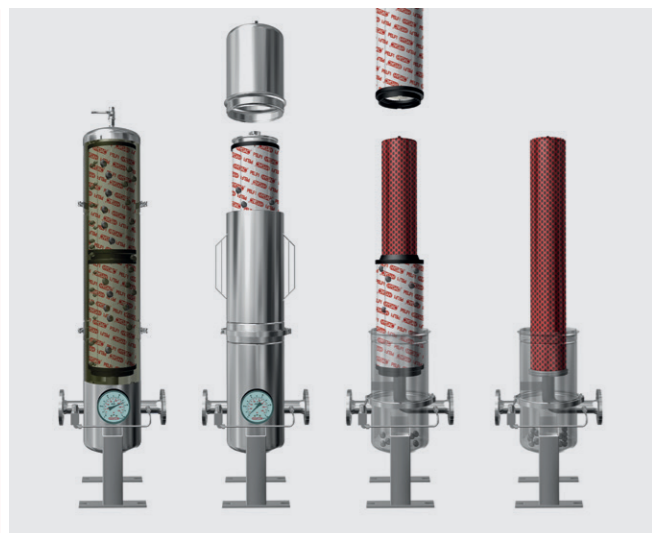

Sectional and functional drawing for PLF1

Specifications	PLF1 Inline Filters
Nominal size	● DN 40 – DN 150
Volume flow Q _{max}	● 200 m ³ /h
Operating pressure p _{max}	● 16 bar
Filtration ratings	● 1 μm to 90 μm

Bodyguard for High Requirements – Inline Filter PLF2 up to 3000 m³/h

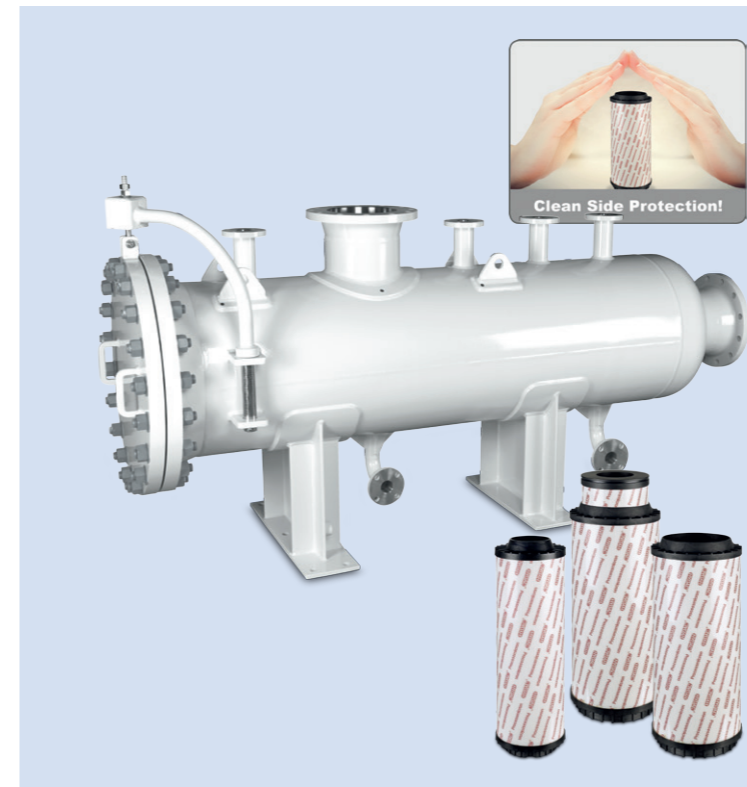

Product description

- Continuous separation of solids from low viscosity fluids
- One-step filter housing for up to 21 filter elements
- Flow rates up to 3000 m³/h

Filter element technology

- High quality filter elements made from polyester or polypropylene
- Multi-layer filter mat construction
- Staged (graduated) depth filtration
- Protection for the clean side

Processmicron® filter elements in 3 versions:



- 1) Work filtration:**
Larger flow surface for higher contamination loads
→ HighFlow 6"



- 2) Comprehensive work filtration:**
Double the safety, even for contamination peaks due cascade effects
→ HighLoadCascade 9"



- 3) Protective filtration:**
High volumetric flows
→ HighFlow 9"

Product advantages

- Excellent deposition rates
- Low pressure drops due to large cross sections and filter areas
- Very large filter area per filter element
- Compact design with high flow rates
- Space-saving horizontal filter design
- Flow-optimised design
- Protection of the clean side during element change
- High contamination retention capacity
- Modular design gives optimal flexibility in catering for every application

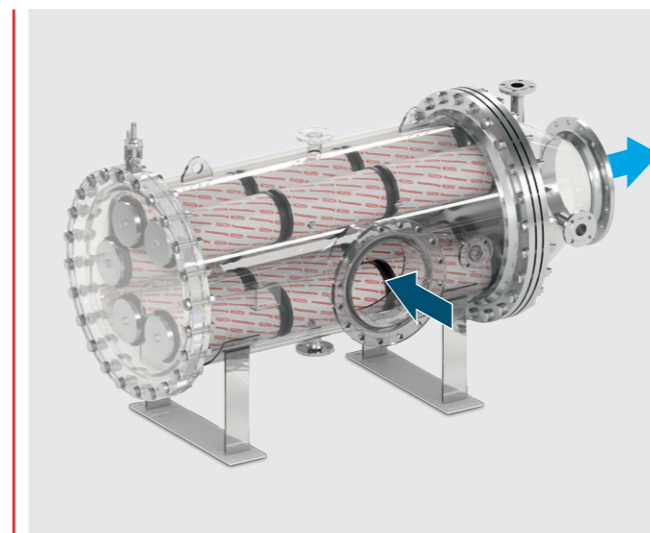

Sectional view PLF2

Specifications	PLF2 Inline Filters
Nominal size	● DN 200 – DN 600
Volume flow Q _{max}	● 3000 m ³ /h
Operating pressure p _{max}	● 16 bar
Filtration ratings	● 1 μm to 90 μm

Processmicron® Filter Elements for Series PLF1 and PLF2

Technical data

- Filtration ratings: 1 µm to 90 µm
- Length: 20", outer diameter 6" or 9"
- Type of filter element pleated or Spun Spray
- Filter material: polyester or polypropylene

Design of Processmicron® Filter Elements

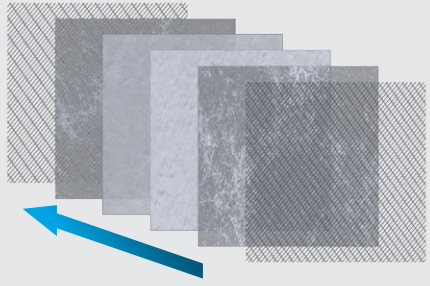

Multi-layer filter mat construction

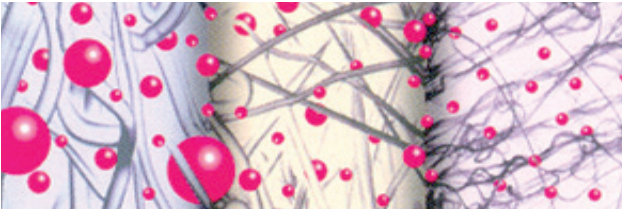

- Robust and high-quality layer structure
→ No skewing of the filter layers
- High contamination retention
- Low pressure loss



Staged (graduated) depth filtration

- High purity in single passage
- High layer thickness of the filter medium
→ High storage volume for contamination

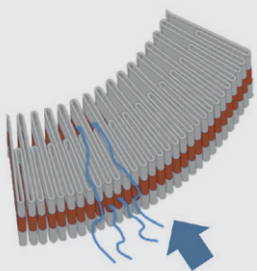
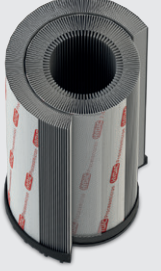
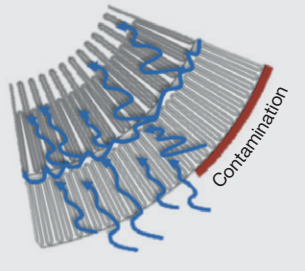
The right filter element for optimal particle filtration

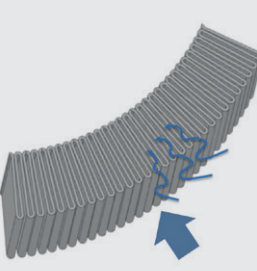
		<h3>HighFlow 6"</h3> <p>Working filtration:</p> <ul style="list-style-type: none"> ● M-pleat ● Optimised, enlarged upstream area for high polluting loads
		<h3>HighLoadCascade 9"</h3> <p>Comprehensive working filtration:</p> <ul style="list-style-type: none"> ● Combination of parallel folds (outside) and M-folds (inside) ● Double security, even with contamination surges, thanks to cascading effect ● Selection of filter layers precisely tailored to the filtration task at hand (outer and inner layers)
		<h3>HighFlow 9"</h3> <p>Protective filtration:</p> <ul style="list-style-type: none"> ● Pleated filter element construction (parallel folding) ● High flow rates ● Extreme fold stability through parallel folding at large filter element circumference

Insurance against Downtimes – Candle Filters PMRF



Product description

- Separation of solid particles from low viscosity fluids
- Suitable for applications with the highest cleanliness requirements
- Tried-and-tested candle filter technology for finest filtration
- Also available as a switchable double filter

Filter element technology

- Filtration ratings: 1 µm to 90 µm
- **Flexmicron Premium:** durable, pleated filter elements (pleat technology) with low layer thickness made from melt-blown or high-quality glass fibres for graduated depth filtration
→ Long service life even in fluids difficult to filter
- **Flexmicron Standard:** Spun Spray depth filter elements (melt-blown) for graduated depth filtration: high cleanliness in a single pass, high filter thickness of filter medium
→ High storage volume for contamination
- **Flexmicron Economy:** Spun Spray depth filter elements (melt-blown) suitable for applications with medium requirements for fluid and type purity
→ Inexpensive solution

Product advantages

- Economic operation through high quality standards, defined filtration rates and high separation values
- Compact housing with high flow rates
- Service-friendly for filter element change
- Efficient system and component protection
- Environmentally safe disposal, as incinerable

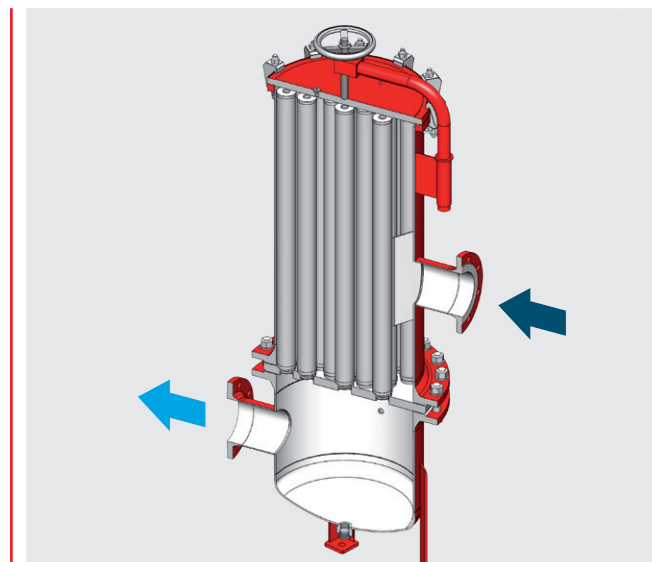

Sectional view PMRF

Specifications	PMRF Candle Filters
Nominal size	● G 1" – DN 250
Volume flow Q_{max}	● 1200 m³/h
Operating pressure p_{max}	● 40 bar
Filtration ratings	● 1 µm to 90 µm



Accumulator Technology 30,000

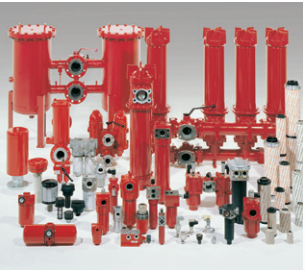

Filter Technology 70,000



Process Technology 77,000



Filter Systems 79,000

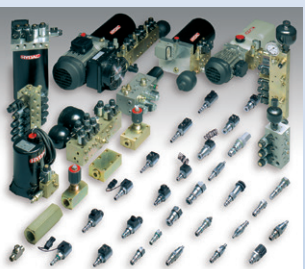

Compact Hydraulics 53,000



Accessories 61,000



Electronics 180,000



Cooling Systems 57,000

Global Presence. Local Expertise. www.hydac.com

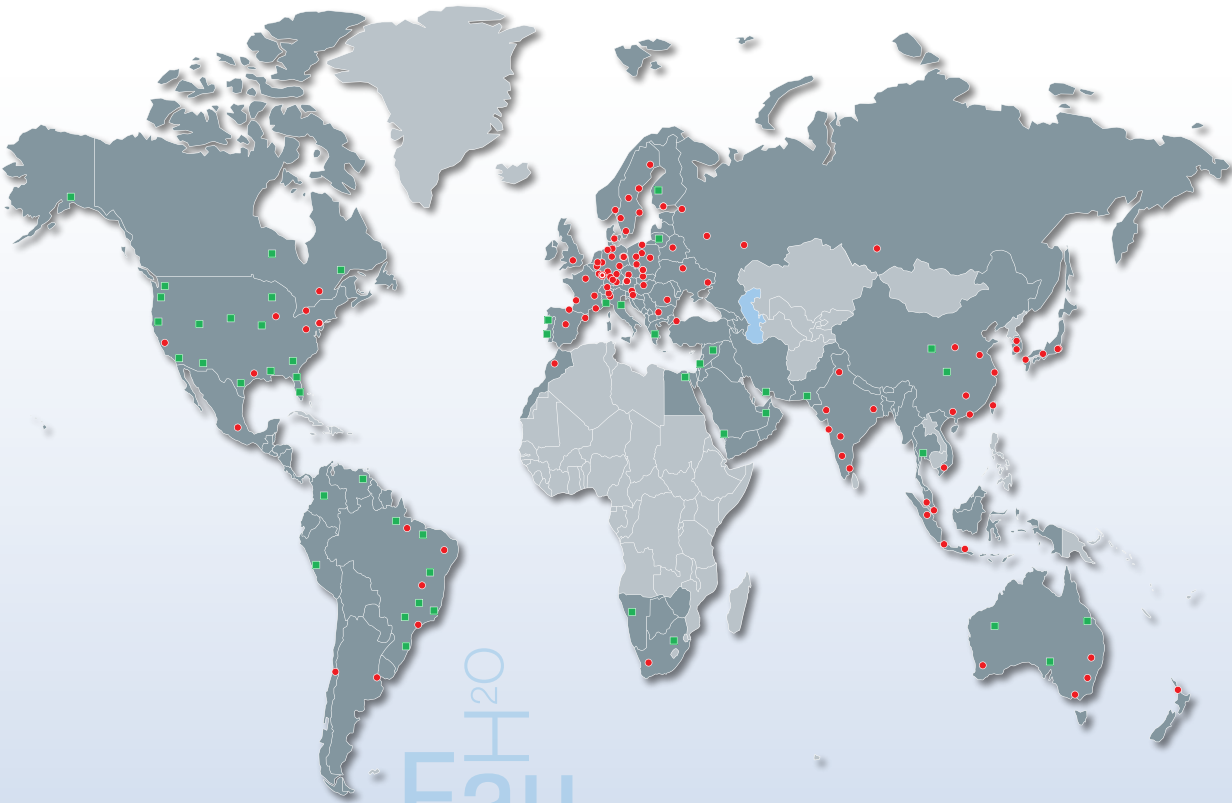

- HYDAC Headquarters
- HYDAC Companies
- HYDAC Sales and Service Partners

HYDAC INTERNATIONAL

Head Office
HYDAC Process Technology
GmbH

Industriegebiet Grube König
Am Wrangelflöz 1
66538 Neunkirchen
Germany

Tel.: +49 6897 509-1241
Fax: +49 6897 509-1278

E-mail: prozess-technik@hydac.com
Internet: www.hydac.com